

SANKO

ニードル アイ
Needle Eye
Watchman for dangerous needles

NEEDLE & IRON PIECE DETECTOR FOR APPAREL

アバ APĀ-3000

INSTRUCTION MANUAL



※ ※ ※ REQUEST ※ ※ ※

- Please read this instruction thoroughly to become completely familiar with the operation to avoid possibility of mistake in detection.
- Always keep this instruction beside the instrument for your reference.

SANKO ELECTRONIC LABORATORY CO., LTD.

株式会社サンコウ電子研究所

(K.K. SANKO DENSHI KENKYUSHO)

Request

- ★ Read this instruction thoroughly to become completely familiar with the operation to avoid possibility of mistake in detection.
 - ★ Keep this instruction beside the instrument for your reference.
 - ★ Any loss caused by missing needles through detections by this instrument cannot be covered by the manufacturer and/or dealers.
- This instrument is essentially aimed at decreasing the numbers of straying needles. Perfect detection of the needles are not warranted.

CONTENTS

	Page
Principle, Special features, Applications, Specifications	1
Special precautions for use	2
Name of parts	3
How to set the detector	4
Preparation	5
Confirmation of detecting ability	6
Method of needle (stray needle) inspection	7
Notice in the inspection for needle detection	8
If you think "Is it a trouble ?"	9
Other types of SANKO NEEDLE AND IRON PIECE DETECTOR	10

Principle :

APA-3000 is the magnetic induction type iron piece and needle detector utilizing the characteristics of a permanent magnet becoming sensitive to moving iron (or steel).

Special features :

- New SAS circuit method :Stable, efficient and high quality detection is applicable to those apparels and clothings fitted with the accessories of fasteners, hooks, buttons and so on.
- Sensitivity selector:Detecting sensitivity is selectable with the electronic sensitivity selector classified into three levels according to kinds of size, quality, etc., of fasteners, hooks, buttons, etc. So it is very powerful for needle inspection of ladies' and men's apparel clothes, and garments.
- High sensitivity :It can be also used as a highly sensitive type needle detector for common clothing articles other than wearing apparel.

Applications :

For inspecting dangerous needles, broken needles and so on which may stray into the following items.

- Apparel clothes for ladies, men etc.
- Children and baby wears etc.
- Night wears like pajamas, nightgown and underwear like undershirts, slips.
- Japanese clothing (Kimono) , embroideries etc.
- General sewing goods, clothing articles, etc.

Specifications :

Name of model:	"Needle Eye" APA-3000
Detecting method:	Magnetic induction method (New SAS Circuit adapted)
Sensitivity selector:	Electronic switch with 3 steps (HIGH, MID, LOW)
Detecting ability:	Against iron needles sized $\phi 0.6 \times 33$ mm • HIGH : Within approx. 11 cm high from detecting surface • MID : Within approx. 10 cm high from detecting surface • LOW : Within approx. 8 cm high from detecting surface
Alarm devices:	Electronic buzzer & lamps
Detecting width:	14 × 55 cm Inside mark []
Power source:	★ AC <u>220V</u> 50/60Hz Consumed power : 15~20W approx.
Dimensions & weight:	40 (W) × 60 (L) × 7 (H) cm Approx. 12 kg
Interchangeble lamp:	★ <u>220 V</u> 5W date-shaped lamp

Design and specifications subject to change without notice.

● SPECIAL PRECAUTIONS FOR USE !!

Made of iron materials only !

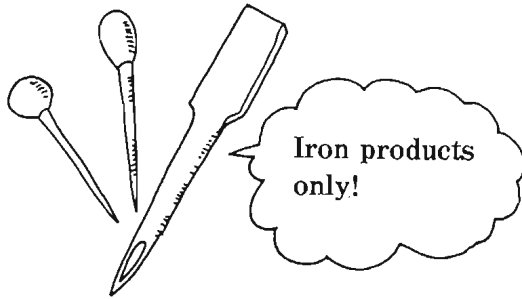

Detectable materials are limited to iron. Needles and pins made of stainless steel, brass and other nonferrous products cannot be detected,

Confirm the power source voltage !

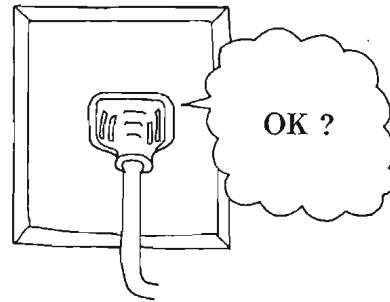

If the main source voltage is different from the specified voltage of the detector, its circuit and parts should be broken.

Objects for inspection must be moved !

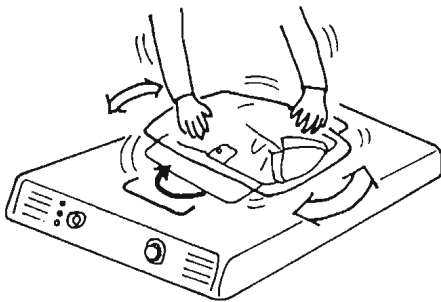

The object to be inspected must be surely moved on the detection surface of the instrument.

INFORMATION CONCERNING THE DETECTION SUPPORT TYPE ACCESSORIES SUCH AS BUTTONS, FASTENERS, HOOKS, ETC.

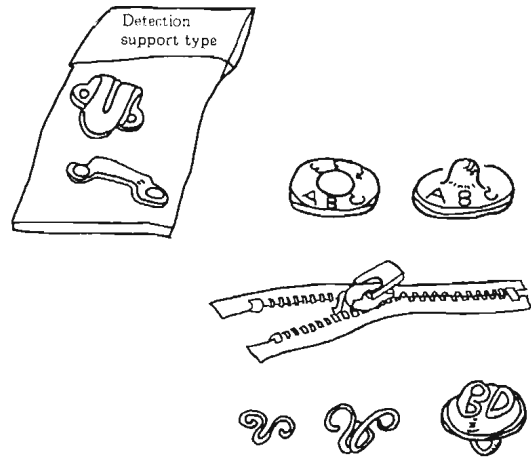

Buttons, fasteners made of metallic materials are sometimes sensed and detected as needles. The detection support type accessories have been developed for decreasing reaction against needle detectors and improving detecting ability.

Confirm whether accessories are detection support type or not, at the stage of planning and designing of clothes manufacture and inspection.

Keep away Magnetic Card, etc. !

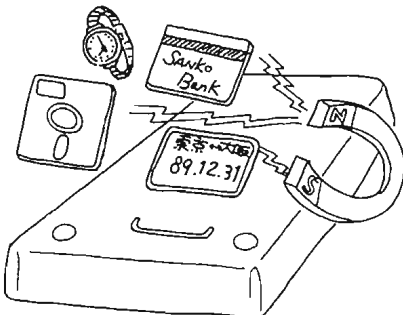

Strong magnetic flux flows near around the detector. Keep away the magnetic memory objects such as cash card, pass, floppy disk, tapes, wristwatch etc.

■ Name of parts :

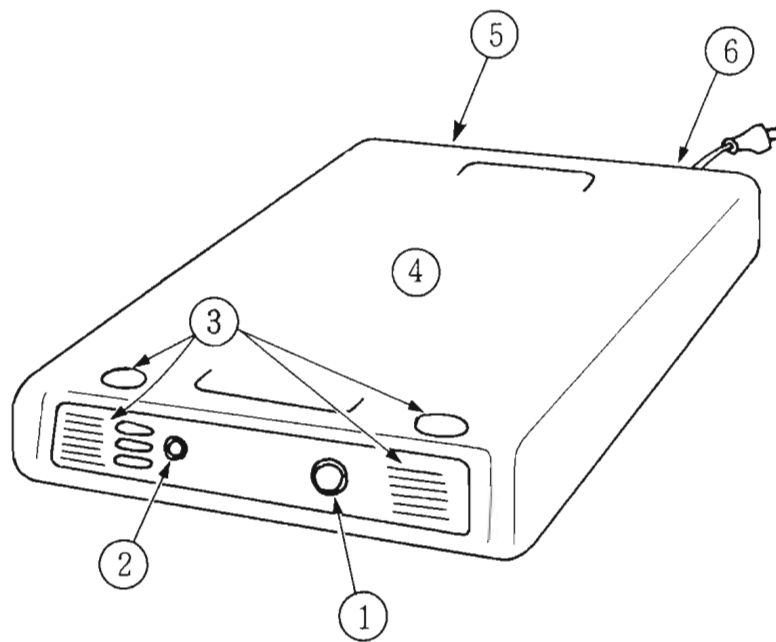

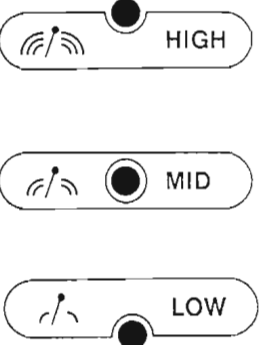
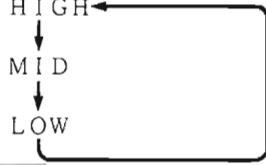
①	Power switch	<ul style="list-style-type: none"> ◆ When pushing the power switch [ON], lamps of ①, ③ light and blink and buzzer ⑤ sounds. ◆ The second blinking of lamps ③ and sounding of buzzer ⑤ at 4 ~ 5 seconds later.
②	Sensitivity selector 	<p>Used for adjusting the detecting sensitivity.</p> <ul style="list-style-type: none"> ◆ When the accessories other than needles are sensed, push the yellow button (HIGH→MID→LOW) until no sensing. ◆ At first [ON] of Power Switch and repeated [ON] after once pushed to [OFF], the sensitivity returns to the highest position [HIGH] ◆ Everytime the yellow sensitivity selector button is pushed, the sensitivity is changed as right figure. 
③	Alarm lamps	The lamps go on with "Power ON" and when needles are detected, the lamps blink.
④	Detecting area	Detecting area is inside the part just enclosed by the mark [] .
⑤	Alarm buzzer	<p>The buzzer goes on, when needles are detected.</p> <ul style="list-style-type: none"> ◆ Also the first buzzer at power [ON] and the second buzzer at 4 ~ 5 seconds later. (See ①)
⑥	Power source cord	<p>The cord reeler is attached.</p> <ul style="list-style-type: none"> ◆ Don't pull the cord out over the red mark. ◆ Don't take it in or out under power [ON] conditions. It may cause the miss-working.

■ HOW TO SET THE NEEDLE DETECTOR

Set the detector on the stable wooden table.

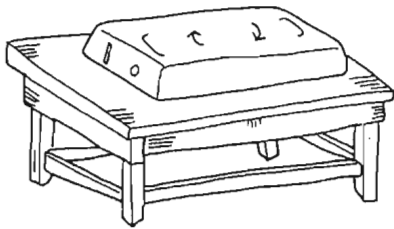

- Use a firm wooden table. Impossible to use steel or metal desks and tables. Also impossible to use tables with steel or metal top and frame.



- Put the table on a firm level place.
- Place the four rubber-made feet of the detector firmly on the table.

● Notice

Don't set the detector near noise sources !

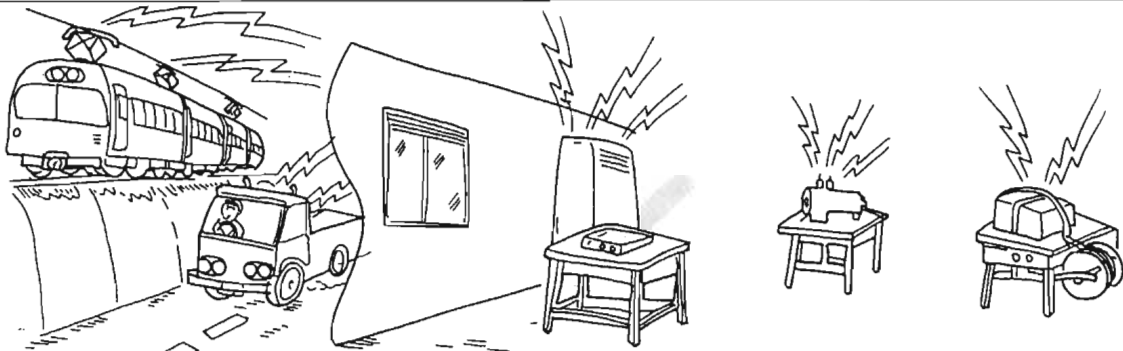

- Don't set near the motors (especially inverter motors) which are the noise source, such as a sewing machine, a cutter machine, a packing machine, an air conditioner and so on.
- To avoid the engine spark noise, high power car radio noise and trolley wire noise, don't set near railways or roads etc.

Keep scissors away !

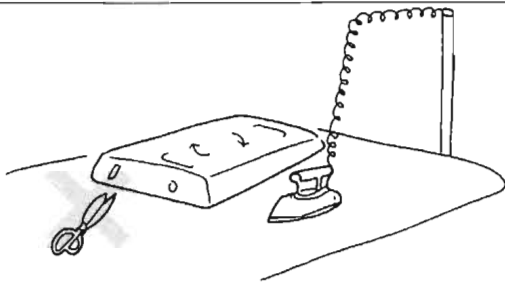

Keep away the iron or metal products such as an iron, scissors, wrist watches and etc.

One plug to one outlet



Multiple plugs to one outlet creates the noise of power sources, etc., which causes the trouble.

■ PREPARATION :

1. POWER[ON] → FIRST TIME BUZZER → SECOND TIME BUZZER

Push the power switch [ON]

The first time buzzer sounds at Power [ON]

The second time buzzer sounds in 4~5 seconds.

Be sure to confirm the second time buzzer sound.

2. Determination of detecting sensitivity

① Confirm the sensitivity selector lamp [HIGH] lighting.

② Move and stir the clothing fixed with accessories over the detector like drawing a circle along the Arrow Marking, while turning over and repeating. Confirm no reaction owing to the fixed accessories.



■ If the buzzer sounds by accessories (buttons etc.)

● Set sensitivity to [MID]

Repeat the operation of ② above. Confirm no reaction by accessories.

■ If there is accessories reaction yet

● Set sensitivity to [LOW]

Repeat the operation of ② above. Confirm no reaction by accessories.

■ If there is accessories reaction yet.

● Try various methods. For example detect the clothing before fitting accessories, or while picking up accessories portions above or away from the detecting surface and so on.

To NEXT PAGE

3. CONFIRMATION OF DETECTING ABILITY :

From the page 5

● Confirm no reaction by buttons, fasteners and other accessories at the selected sensitivity.

● Stick a needle of the same size and shape as you want to detect, on the commodities with cellophane tape, etc.
Then test by the same operation as ② at page 5 and confirm you can detect or not.

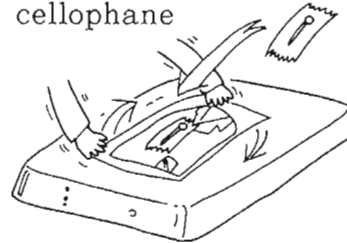

"Iron products only"



Iron is only a material possible for the detection. Needles, pins, made by stainless steel, non-ferrous metal can't be detected.

"Use needles and pins made of iron."

Detection support type accessories for effective detection

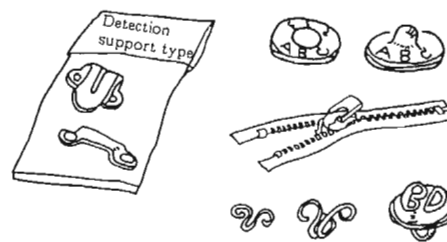

Recommendabl to use buttons, fasteners, hooks etc., of the detection support type. See Page 2 .

Strength of detection ability (Refer to Specifications at page 1.)

● Sensitivity is the strongest on the detection surface and become weaker as further away the surface and senseless at a certain height.

Detection becomes easier as bigger needle and difficult as smaller.

● Confirm the detection ability whenever sensitivity is changed.

Because the ability varies with the change of sensitivity.

※ Iron needles sized $\phi 0.6 \times 33 \text{ mm}$ (Specifications/detecting ability at page 1)

Sensitivity	Sensitivity to standard needles or pins ※	Detection ability	Reaction to accessories
HIGH	Above detecting surface up to abt. 11 cm	↑ Strong (Broken needles can be detected.)	↑ Strong
MID	" abt. 10 cm		
LOW	" abt. 8 cm	↓ Weak (Effective for bigger needles)	↓ Weak

■ METHOD OF NEEDLE (STRAY NEEDLE) INSPECTION :

1. Preparation 1 (Power ON) → Preparation 2 (Setting up detecting sensitivity) → Preparation 3 (Confirmation of detecting ability)

When the above 1,2,3 are completed, the preparation for needle inspection is OK.

2. Needle inspection

- Put the commodities for inspection on the detector. Move and stir them round and round along the arrow marking.



- Move the commodities for inspection. Only to stay without moving does not serve for detecting needle.

- Detecting area is confined to the inside part just enclosed by the mark []. Detection is impossible outside mark [].

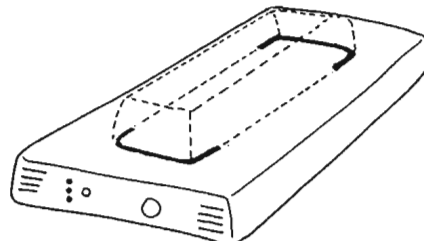

Refer to "Strength of detection ability at page 6.

- If needles are detected, alarms (lamps and buzzer) go on.

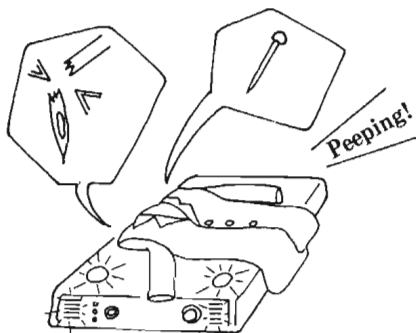

- In case the commodities are thick or bulky, repeat inspection by turning them over or holding them down lightly.



- The appropriate speed to be moved is 50~80cm/sec. Generally to move speedily is better than to move slowly.

- After taking out the detected needle, be sure to repeat inspection again to confirm that no needle is left.

- There are some cases in which 2 ~ 3 needles stray together into the same item. Another detection should be repeated.

NOTICE IN THE INSPECTION FOR NEEDLE DETECTION

Iron products only !

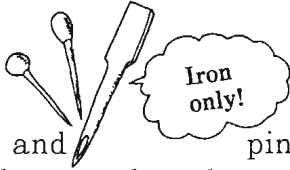

Needles and pins made of stainless steel and non-ferrous metals can't be detected. Use iron needles and pins.

Reversed side also in case of thick clothes

- Thick and bulky commodities are lightly held down while inspecting both sides.

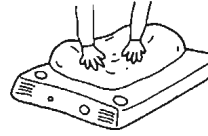

Detection support type accessories

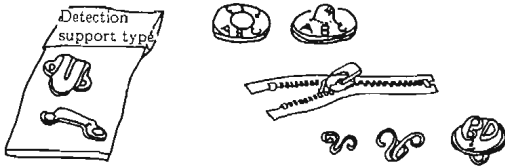

See Page 2

Turn commodities when inspecting

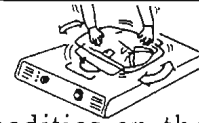

- Move commodities on the detecting area when detecting needles.
- Detection ability depends on the direction of needles. Move and turn the clothes, not only length wise but also sideways.

Possible Height for detection

- Arrange the needles to be detected to pass within the possible height for detection.
- The nearer to the detector, the stronger the sensitivity is, and further, the cannot be detected.
- The possible height for detection depends on the selection of the sensitivity. See Page 6

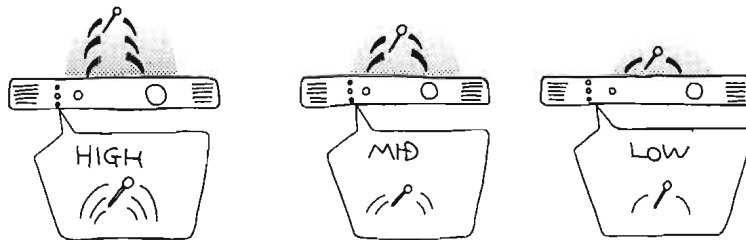

➔ Impossible to detect needles above the possible height.

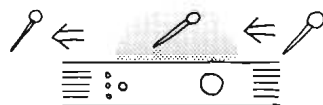

➔ Put and move the inspecting commodities close to the detector as much as possible.

If you think "Is it a trouble?"

- Check the following points before asking for repairing or service.

Trouble	Check points	How To Repair
When power source switch is on, the lamp doesn't light up	● Is a plug inserted into an outlet correctly ?	● Insert a plug into the outlet correctly.
	● Does the buzzer sound when a needle or pin is moved on the needle detector ?	● When buzzer sounds → the lamp is broken. Take off the plug from the outlet. Open the back cover and change to the new lamp mentioned in the specifications (page 1). ● When buzzer doesn't sound Contact the dealer where you bought it.
At Power Switch on, the power lamp ① lights but the alarm lamps ③ and buzzer ⑤ sound doesn't go on-and-off.		● Contact the dealer where you bought it.
Though a needle is not detected, the buzzer sometimes sounds or continues sounding.	● Is the detector or table firmly set ?	● Set the detector firmly
	● Don't you use a steel desk or a table with steel legs ? ● Is the detector put directly on the floor ?	● Set the detector on the firm wooden table.
	● Are an iron or scissors etc., placed near the detector ?	● Keep away the iron product such as an iron or scissors etc.
	● Are needles or staples stuck to the back of the detector ?	● Remove the needles or staples stuck to.
	● Are there the motors which are the noise source, such as a sewing machine, a cutting machine, a packing machine or an air-conditioner near the detector.	● To avoid the engine spark noise, high power car radio noise and trolley wire noise, etc., don't set near railways or roads. ● Keep the detector away from the noise source (especially inverter sewing machine) as far as possible. ● Only if the direction of the detector changes (length-wise and sideways.) noise influence may be avoided.

■ When the detector is not repaired ever after checking those points, contact the dealer where you bought it.

SANKO NEEDLE AND IRON PIECE DETECTORS FOR NEEDLE DETECTING SYSTEM

SANKO NEEDLE AND IRON PIECE DETECTORS have a variety of the full models capable of keeping up with various kinds of uses. These models are very helpful for improving the management of inspection and quality control.

SK-1200 Ⅲ (Table type)



Standard model

SK-6 (Table type)



Small type saving space

TY-30 (New handy type)



Selectable Wide or Spot
Range for efficiency.

TY-20N (Handy type)



Handy in your pocket
Effective to locate needles

TY-20S (Stick type)

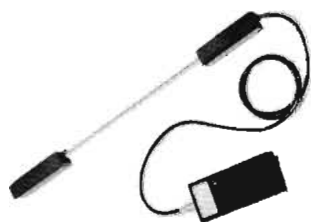

For items on hangers, etc.

Conveyer type SF series/APA-6000



Automatic and only belt-On

SK-12TR (Wide length type)

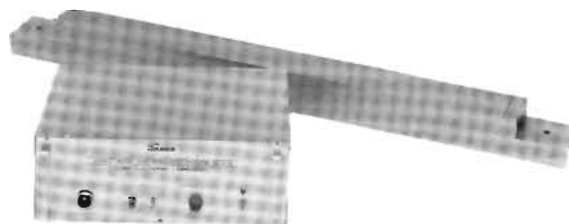

On-line system detection for cloth, textile, carpet, etc.
Up to 4 meters with the partial signal function.



Precision Measuring Instruments

- Coating Thickness Measuring Meter
(Dual, Electro-magnetic and Eddy Current Types)
- Pinhole and Holiday Detector
(High Voltage Spark and Dampened Roller Types)
- Needle and Iron Piece Detector
- Infrared Moisture Meter
(Balance Type)
- Electric Moisture Meter
(For Wood, Paper, Mortar, Plaster, etc.)

SANKO ELECTRONIC LABORATORY CO., LTD.

株式会社サンコウ電子研究所

(K.K. SANKO DENSHI KENKYUSHO)

Manufacturer:

Sanko Electronic Laboratory Co.,Ltd.

- Tokyo branch** : Shibata bldg., 2-6-4 Uchikanda, Chiyoda-ku, TOKYO 101-0047, Japan
Telephone: 81-3-3254-5031 Fax: 81-3-3254-5038
- Osaka branch** : Konishi bldg., 2-3, Sugawara-cho Kita-ku, OSAKA 530-0046, Japan
Telephone: 81-6-6362-7805 Fax: 81-6-6365-7381
- Nagoya branch** : Meihoku bldg., 3-11-27, Kinjo, Kita-ku, NAGOYA 462-2847, Japan
Telephone: 81-52-915-2650 Fax: 81-52-915-7238
- Fukuoka branch** : 11-11 Naraya-cho, Hakata-ku FUKUOKA 812-0023, Japan
Telephone: 81-92-282-6801 Fax: 81-92-282-6803
- Head office** : 1677 Hisasue, Takatsu-ku, KAWASAKI 213-0026, Japan
Telephone: 81-44-751-7121 Fax: 81-44-755-3212

URL <http://www.sanko-denshi.co.jp> E-mail info@sanko-denshi.co.jp