



ELECTRIC MOISTURE METER
MOISTURE METER FOR BUILDING MATERIAL

A Q - 3 0
- AQUA SERIES -

I N S T R U C T I O N M A N U A L

CAUTIONS:

Before using the Meter, read this INSTRUCTION MANUAL thoroughly and use the Meter correctly.

Keep this INSTRUCTION MANUAL carefully and refer to this, when necessary.

In the event of any doubt arising, the original INSTRUCTION MANUAL in Japanese is to be final authority.

SANKO ELECTRONIC LABORATORY CO.,LTD
(株式会社 サンコウ電子研究所)

CONTENTS

ITEM	PAGE
1 APPLICATION	2
2 SPECIFICATIONS	2
3 PARTS IDENTIFICATION	3
4 OPERATING INSTRUCTIONS	4
4-1 Power ON/OFF	4
4-2 Converting the measuring mode	4
4-3 Converting the hold mode	4
4-4 Converting the key lock mode	4
4-5 Measurement	4
4-6 Auto power OFF	4
5 TEMPERATURE COMPENSATION	5
6 NOTES FOR THE MEASUREMENT	6
7 BATTERY	6
7-1 Indication of the voltage drop	6
7-2 Handling while the Meter is not in use	6
8 MAINTENANCE AND INSPECTION	6
9 MISCELLANEOUS	7
9-1 How to use the Moisture reading checker(option)	7
9-2 Cover for the needle electrode	7



Before using the Meter, read this INSTRUCTION MANUAL thoroughly and use the Meter correctly.

Keep this INSTRUCTION MANUAL carefully and refer to this, when necessary.

1 . APPLICATIONS

Moisture measurement, inspection control and instruction of soft/hard wood and following paper, mortar/concrete and plaster, etc.

Wood:

- Log, sewn lumber, seasoned wood, wood for buildings, fittings, panels and packings
- Plywood, veneer, textile wood, laminated wood, various board, floorings, etc.
- Wooden works/parts such as desk, chair, furniture, etc.

Paper:

- High quality paper, craft paper, paper board, wall paper, other paper and products
- Corrugated paper, paper bag, paper vessel, internal paper, other paper products and semi-processed goods
- Moisture control and check of the old paper etc. such as used news paper and magazine while storing and keeping.

Mortar and Concrete:

- Mortar, concrete, plaster, etc.
- Quality control of base materials for finish coating, tiling, clothing, etc.
- Quality control of various water proofing and decorating works, etc.
- Prevention of claim after completing the work

Moisture condition of various objects can be checked simply and quickly in the MC mode.

2 . SPECIFICATIONS

Name and type	Moisture meter for building material AQ-30
Measuring method	DC electric resistance method
Measuring range	Wood: 6.5 to 100% (SOFT(soft wood), HARD(hard wood) by conversion) Paper: 6.5 to 30% (all paper products) Mortar: 2 to 11% (concrete and plaster) M/C mode: 1 to 50 division (no unit, comparison of moisture)
Resolution	0.5%, 1%, 2%, 5%, 10%, 20% (Depend on measuring range and mode) M/C mode: 1
Indication	LCD digital with hold function
Temperature compensation	Automatic temperature compensation (Available for ON/OFF)
Power source	Alkaline dry batteries LR03(1.5V) × 2 pcs. With auto power off function
Operating temperature	0 to 40 (except dew condensing condition)
Dimensions and Weight	56(W) × 123(H) × 34(D)mm, Approx.100g
Accessories	Spare needles, Hexagonal wrench, Conductive rubber electrode, Cover for needle electrode
Option(Attachment)	SB wire gauze electrode, Roller electrode Moisture reading checker

Specifications and appearance are subject to modify for improvement without prior notice.

3 . PARTS IDENTIFICATION

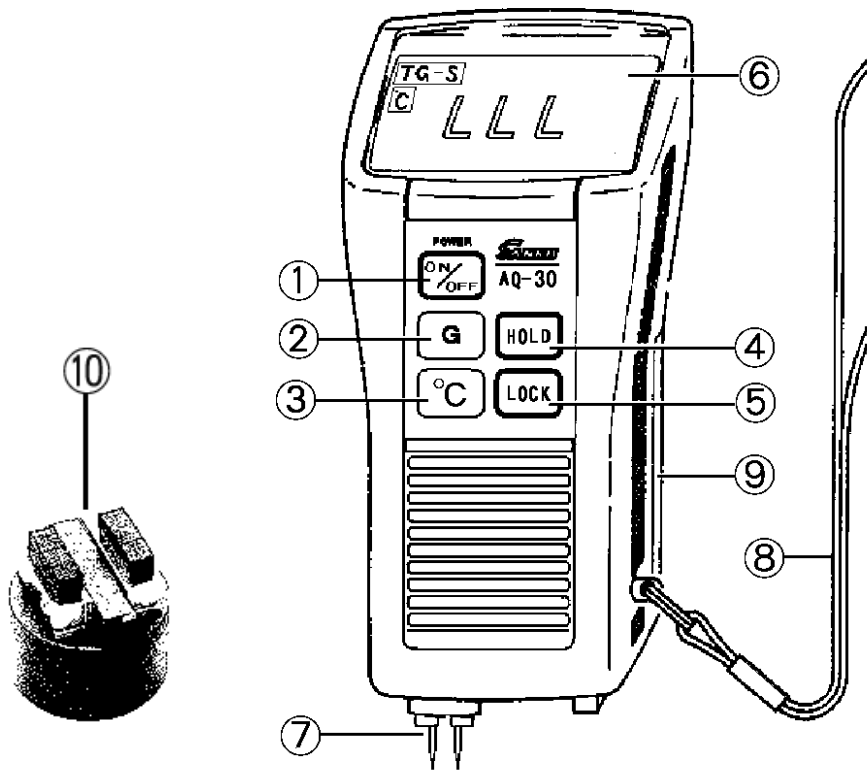

- | | |
|---|---|
| Power key | Key for power ON/OFF |
| G key | Key for converting the measurement mode |
| key | Key for ON/OFF the automatic temperature compensation |
| HOLD key | Key for ON/OFF to hold the measured values |
| LOCK key | Key for locking all keys except ON/OFF key |
| LCD display | Indicating part of the measured values, mode, etc. |
| Electrode part | 2 needle electrode part |
| Hand strap | |
| Lid of the battery case(Backside of the Meter) | |
| Conductive rubber electrode. Insert in the electrode part | |



Be sure to pass the hand strap around the wrist to prevent the Meter from dropping.

4 . OPERATING INSTRUCTIONS

4-1 Power ON, OFF

- Remove the cover for the needle electrode of the electrode part and press the 「POWER」 key .
- [LLL], measurement mode [TG-S] and temperature compensation [] are indicated on the LCD display .
- Press the 「POWER」 key again, then the power OFF.
When the 「POWER」 is repeated quickly the switching over ON/OFF, it may cause malfunction. In this case, power ON again in 2 to 3 minutes.

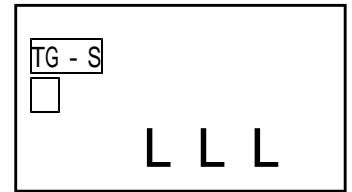

4-2 Converting the measurement mode

- Press the 「G」 key and select the measurement mode.
TG-S: Soft wood TG-H: Hard wood Mo: Mortar and Concrete
P ρ: Plaster KG: Paper MC-S: Moisture comparison mode
- The measurement mode is converted each press of the 「G」 key as follows.



- The selected mode is indicated in the upper part of the LCD display .
- When power ON again after power OFF once, the mode will automatically return back to the [TG-S] mode.
- Be sure to confirm the mode when the measurement is carried out.

4-3 Converting the hold mode

- When the 「HOLD」 key is pressed, the [HOLD] is indicated in the lower right part of the LCD display and the mode is switched over to the hold mode.
The indicated measured value will be held until the next measurement.
- The holding function of the measured value is released by pressing the 「HOLD」 key again and the indicated [HOLD] on the LCD disappears.

4-4 Converting the key lock mode

- When the 「LOCK」 key is pressed, all keys except the 「POWER」 key are locked and misoperation can be prevented.
The key lock mode is released by turning the power OFF.

4-5 Measurement

- Stab the 2 needle electrode into an object to be measured and read the indicated value after settlement of the indication.
- When the needle electrode can not be used to an object to be measured, use the attached conductive rubber electrode inserting in the 2 electrode part . (Same for paper, mortar/concrete and plaster)
When the electrode is loose, tighten by turning the side screw with the hexagonal wrench.
- When the measured value exceeds or under the measuring range, [LLL] or [HHH] is indicated on the LCD display.

4-6 Auto power OFF

- When new measured values are not inputted for about 3 minutes or more, the Meter is automatically power OFF to prevent the consumption of the battery.
- When the electrode part is contacting with an object to be measured, auto power OFF function may not work occasionally.

5 . TEMPERATURE COMPENSATION

The automatic temperature compensating function is set ON at the initial setting condition of the Meter and the indicated values is automatically temperature compensated based on 20 .

ON or OFF of the automatic temperature compensating function is converted by pressing the 「 」 key .

When this function is set ON, the [] is indicated on the LCD display and is not indicated in case of setting OFF.

Ex: In case the temperature compensation is set OFF

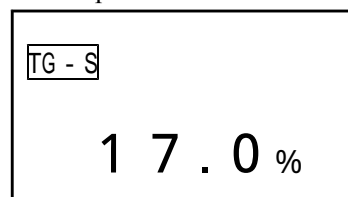

When the automatic temperature compensating function is set OFF, refer to the following list for the temperature compensation.

For Wood

Temperature ()	Moisture (%)		
	4 to 11	12 to 20	21 and over
under 0	+ 2.0	+ 2.5	+ 3.0
0 to 1	+ 2.0	+ 2.5	+ 3.0
2 to 3	+ 2.0	+ 2.0	+ 3.0
4 to 5	+ 1.5	+ 2.0	+ 2.5
6 to 7	+ 1.5	+ 1.5	+ 2.0
8 to 9	+ 1.0	+ 1.5	+ 2.0
10 to 11	+ 1.0	+ 1.0	+ 1.5
12 to 13	+ 1.0	+ 1.0	+ 1.0
14 to 15	+ 0.5	+ 0.5	+ 1.0
16 to 17	+ 0.5	+ 0.5	+ 0.5
18 to 19	0	+ 0.5	+ 0.5
20 to 21	0	0	0
22 to 23	0	- 0.5	- 0.5
24 to 25	- 0.5	- 0.5	- 0.5
26 to 27	- 0.5	- 0.5	- 1.0
28 to 29	- 1.0	- 1.0	- 1.0
30 to 31	- 1.0	- 1.0	- 1.5
32 to 33	- 1.0	- 1.5	- 2.0
34 to 35	- 1.5	- 1.5	- 2.0
36 to 37	- 1.5	- 2.0	- 2.5
38 to 39	- 2.0	- 2.0	- 3.0
40 and over	- 2.0	- 2.5	- 3.0

For Paper, Mortar/Concrete and Plaster

Temperature in measurement	Compensating values to the indication
Over 20	- 0.1% per temperature 1
20 or under	+ 0.1% per temperature 1

6 . NOTES FOR THE MEASUREMENT

Measuring values may disperse according to measuring circumstances.

Electric Resistor Type Moisture meters use the applications of sensitively electric characteristics of measuring objects against the moisture contents and the corresponding relations never be a perfectly correlative one-to-one.

In case of measuring with different compositions • combinations, albeit the same material, and with changes in quality, salt, contamination, and furthermore with special processing, chemical treatments, it may be necessary to avert measuring such unfavorable objects, and compensate or average measured values. As for compensating, it is in general, based on moisture measurement methods in accordance with a drying process.

7 . BATTERY

7-1 Indication of the voltage drop

When [BAT] showing the voltage drop is indicated in the lower left of the LCD display , the batteries close to the limit of use due to consumption.

- Open the battery case on back side by sliding the lid sideward, take out the battery case of the Meter taking care the wiring and replace all alkaline dry batteries LR03(1.5V) 2 pcs. with new ones. (ensure the limit of use).

When the Meter is continuously used after voltage drop mark [BAT] was indicated on the LCD display, following condition will occur.

- Though it differs depending on the characteristics and using condition of the dry batteries, the Meter can work for several hours. (Replace all 2 batteries with fresh ones earlier.)
- When the Meter is continuously used as it is, measured values will become unstable.
- When the 「POWER」 key is turned ON, the buzzer continuously sounds and key operation become impossible simultaneously. (Remove the batteries from the Meter.)
- When no indication is on the LCD display, the batteries are completely consumed.

7-2 Handling while the Meter is not in use

- Even if the 「POWER」 key OFF, the battery capacity has been slightly consumed.
- In case the Meter will be not used for 1 month or more, it is recommended to store the Meter after removing the batteries from the case.

8 . MAINTENANCE AND INSPECTION

- Wipe dirt off with soft cloths, etc. after using the Meter.
Specially care to keep the electrodes and groove between the electrodes, etc. clean and dry.
- Prevent the Meter from exposing to shock, direct sunlight, high temperature, high humidity, etc.
- Select a dust free, clean and well-dried place for storing the Meter.
- In case the Meter will be not used for 1 month or more, remove the batteries from the Meter.

Indication of battery's voltage drop

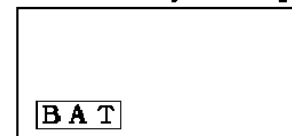

The lid of the battery case

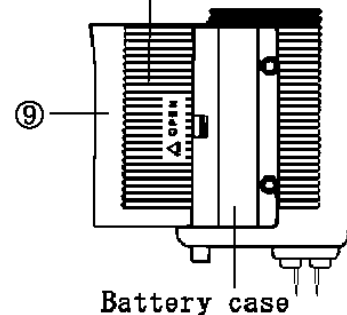

9 . MISCELLANEOUS

9-1 How to use the Moisture reading checker(option).

Press the electrode against the checker as shown in the following sketch in power ON condition.
When the reading of the Meter matches the figure on the checker, the Meter's reading is acceptable.
When the reading deviates from the checker's, please request our agent or the nearest our branch to calibrate the Meter.

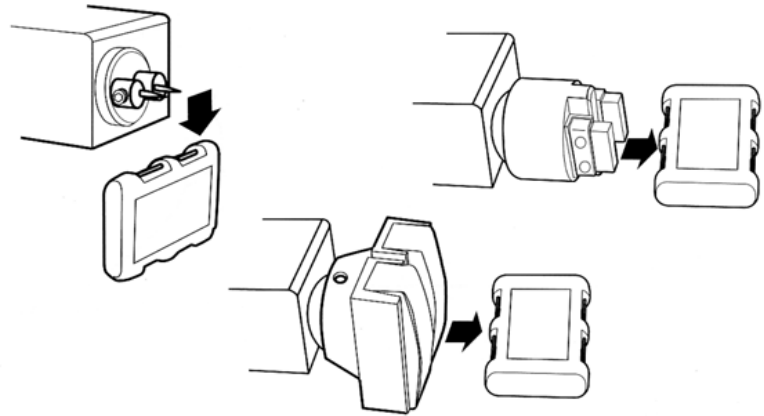

An object for checking by the Moisture reading checker differs the face side from the back side.
Use after surely confirming model, type of the Meter and measurement mode.
When checking the Meter, carry out after turning the temperature compensating function OFF.
Refer to " 5. TEMPERATURE COMPENSATION " in detail.

9-2 Cover for the needle electrode(Fitting/removing methods of the cover)

Fit the cover in the needle electrode spreading out by fingers holding both sides of the cover for the electrode.

When the cover is tight, fit by force prying it.

Carry out the same procedure for removing the cover.

Fitting/removing the cover by force causes an injury occasionally.

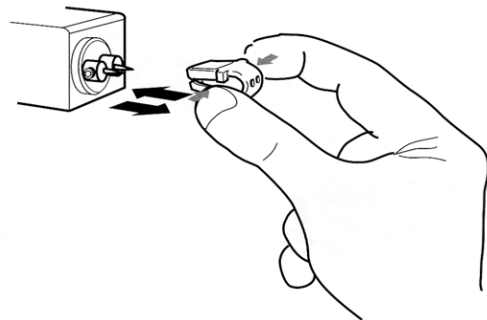

Be careful not to be injured with the Needle electrode

Show rooms:

You are welcomed to the show rooms located at the following places.

- Tokyo show room near the Otemachi station of the subway
- Osaka show room at Tenjinbashi-kitazume
- Nagoya show room near the Kurokawa station of the subway
- Fukuoka show room near the Gofukucho station of the subway

Products sold:

Sales of Coating thickness meter, Pinhole detector, Condensator, Viscosity cup, Moisture meter, Needle detector, Iron piece detector

Manufacturer:

Sanko Electronic Laboratory Co., Ltd.

Tokyo branch Shibata Bldg., 2-6-4, Uchikanda, Chiyoda-ku,
Tokyo 101-0047, Japan

Tel 81-3-3254-5031 Fax 81-3-3254-5038

Osaka branch Konishi Bldg., 2-3, Sugawara-cho, Kita-ku,
Osaka 530-0046, Japan

Tel 81-6-6362-7805 Fax 81-6-6365-7381

Nagoya branch Meihoku Bldg., 3-11-27, Kinjo, Kita-ku,
Nagoya 462-0847, Japan

Tel 81-52-915-2650 Fax 81-52-915-7238

Fukuoka branch 11-11 Naraya-cho, Hakata-ku
Fukuoka 812-0023, Japan

Tel 81-92-282-6801 Fax 81-92-282-6803

Head office 1677 Hisasue, Takatsu-ku,
Kawasaki 213-0026, Japan

Tel 81-44-751-7121 Fax 81-44-755-3212