



SANKO Coating Thickness Meter

SWT – 7 2 0 0

Instruction Manual



CAUTIONS:

Before using the Meter, read this INSTRUCTION MANUAL thoroughly and use the Meter correctly.

Keep this INSTRUCTION MANUAL carefully and refer to this when necessary.

In the event of any doubt arising, the original INSTRUCTION MANUAL (Japanese) is to be of final authority.

SANKO ELECTRONIC LABORATORY CO., LTD.

Tokyo • Osaka • Nagoya • Fukuoka • Kawasaki

Contents	Pages
Attention for safety	1
Notes	4
Get started	5
• Contents in a package.....	5
• Names of part	6
• Items indicated on LCD	8
• How to fit batteries	9
• How connect, disconnect probes	10
• How to hold probes	11
• How to press a probe to an object	11
How to operate	12
(1) How to switch power source	12
(2) How to switch off	13
(3) How to select 「calibration no. 」	14
(4) Zeroing	16
(5) Zeroing in special cases	18
(6) Calibration standard	21
(7) How to delete calibration	24
Function switching	25
(1) Switching to Non-Interrupt Measurement Mode	25
(2) Switching to resolution	27
(3) Switching to Key Lock Mode	28
Measuring	29
Setting High/Low limits value	30
(1) Setting a High limit value	30
(2) Setting a Low limit value	31
(3) Deleting a set limit value	33
Measurements with High · Low limit values	34

Contents	Pages
Storing measured values	3 5
(1) How to select a data storing place	3 6
(2) How to keep data from being stored	3 9
Measurements in storing data	4 0
1 Deletion of data	4 5
Deletion of data	4 6
Deletion of data (group)	4 8
Deletion of data (block)	5 0
Deletion of data (section)	5 3
Statistics	5 6
(1) Statistics of 「all data」 stored	5 6
(2) Statistics of data stored in 『group No.』	5 7
(3) Statistics of data stored in 『block No.』 of a group	5 9
(4) Statistics of data stored in 『section No.』 in a block of a group	6 2
Transferring data—① USB (real time transfer)	6 5
Transferring stored data—② USB (all data transfer)	6 7
Transferring stored data—③ USB (group numbers data transfer)	6 9
Transferring data—④ USB (block numbers data transfer)	7 2
Transferring data—⑤ USB (section numbers data transfer)	7 5
Note to improve measuring accuracy	7 9
Trouble shooting	8 0
Specifications ◆ main unit	8 3
◆ probe (optional)	8 4
References (measurement principles)	8 5

Attention for safety (to use in correct ways)

To prevent you and your properties from damaging please take some time to read thoroughly this “Attention for Safety” and correct uses keep these instructions attentive to read when necessary.



Warning

-  ● Do not dump nor wet the gauge unit in water, otherwise it may cause damages.
Keep off water Please contact our distributor or sales office should submerged water into the unit.
-  ● Keep metals or foreign substances from the unit, otherwise it may cause damages.
Prohibition Please contact our distributor or sales office should put any materials or foreign substances in the unit.
-  ● Do not insert a screwdriver into the connector, otherwise that it may cause damages.
Prohibition
-  ● Do not throw, smash, drop the unit, otherwise it may cause damages.
Prohibition
-  ● Never dismantle or modify the gauge unit by yourself, otherwise it may cause errors or damages.
Dismantling prohibited
-  ● Do not use AC adaptors other than an exclusive adaptor for this unit,
Prohibition otherwise it may cause damages, electric shocks, fires.
-  ● Please use the exclusive adaptor with a designated Voltage only, otherwise it may cause
Prohibition damages, electric shocks, fires.
-  ● Keep the terminals of the adaptor free from metal pieces or dust, otherwise it may cause short circuit,
Prohibition electric shocks, fires.
-  ● Do not handle the AC adaptor with wet hands, otherwise it may cause electric shocks.
Prohibition
-  ● Do not damage, brake, modify, forcefully bend or twist the cord of the AC adaptor. Or, do not load it with
Prohibition heavy staff or pinch it forcefully, otherwise it may cause breaking wires, short circuit, fires.

Attention For Safety (to use safely and correctly)





Warning

-  ● Never fail to remove batteries from the unit when not in use for a long time.
Must Leakages occurred from deterioration of batteries may cause erroneous reactions or damages.

-  ● Be sure to read this book on the item of 「How to fit batteries」 to replace batteries.
Must

-  ● Store batteries in a place where children and pets are incapable of handling them.
Must Please call a doctor like in a case that a battery is swallowed.

-  ● Do not put batteries into fire or water. Store them in a cool, dry and dark place avoiding flames, high temperature and moisture.
Must

-  ● Do not get batteries shocked and dismantled, and soldered for processing
Must

-  ● Do not short or recharge batteries and handle with metallic tools like pliers.
Must

-  ● Replace with new(unused) batteries according to the procedure of this Operating Instructions.
Must

-  ● Be sure of paying attention on battery polarity marks, (+、-) to place the batteries.
Must

-  ● In case a battery has leakage please clean up the place with clothes to replace batteries.
Must And do not touch the leaked liquid and wash skins or clothes in case they are contaminated.

-  ● Comply to regulations and laws in your neighbors when disposing of them.
Must

-  ● Insert a plug of the AC adaptor to the full end, otherwise it may cause electric shocks and fires with burns. And do not use faulty or loose receptacles.
Must

-  ● Switch to OFF and unplug the AC adaptor from the receptacle to avoid electric shocks and damages when inspecting or cleaning the gauge .
Must

Attention For Safety (to use safely and correctly)



Attention

-  ● Do not use Benzene or Thinner for cleaning and spray pesticides on the meter, otherwise it may cause cracks or malfunctions.

Prohibition
-  ● Do not store the meter in places getting high in temperatures such as in a car in strong sunlight or near heaters, otherwise it will be hazardous to the meter and may cause malfunctions.

Prohibition
-  ● Do not step, trample down nor put anything on the meter.

Prohibition
-  ● Keep the meter away off rubber-made articles or vinyl articles. A lengthy contact between meter and them may cause stickiness and it may be difficult to get rid of them.

Prohibition

Notes:

- Please read this manual thoroughly for correct operations before getting started.
- This meter is a precision gauge. Please handle with care.
- Do not tug, bend, fold or curl up forcefully the cables of probes.
- Do not knock or scratch objects with the tip of a probe.
- Keep the tip of a probe clean. A slight amount of dust may cause errors in measurements.
- Clean the meter and store it in free from dust and moisture after operation.
- To keep precision with a gauge please contact our distributor or our sales office once a year for inspection
- Keep the meter away off electric noises, shocks or magnetic fields when in a use.

Get started

◆ Contents in a package

- Main unit
SWT-7200
- Dry batteries R6P/AA (2 pieces)
- Carrying case
- Instruction manual (this manual)
- Warranty/User resistor sheet (Available only in Japan)
- AC adaptor
- USB cable (2.0m)
- USB driver (CD)

● In case of an optional probe

- Probe
For ferrous(Fe), or non-ferrous(NFe)
- Zero boards for testing (for Fe:ferrous substrates/for NFe:non-ferrous substrates)
- Thickness standards(films :2 sheets, bake:1 sheet)

◆ Names of part

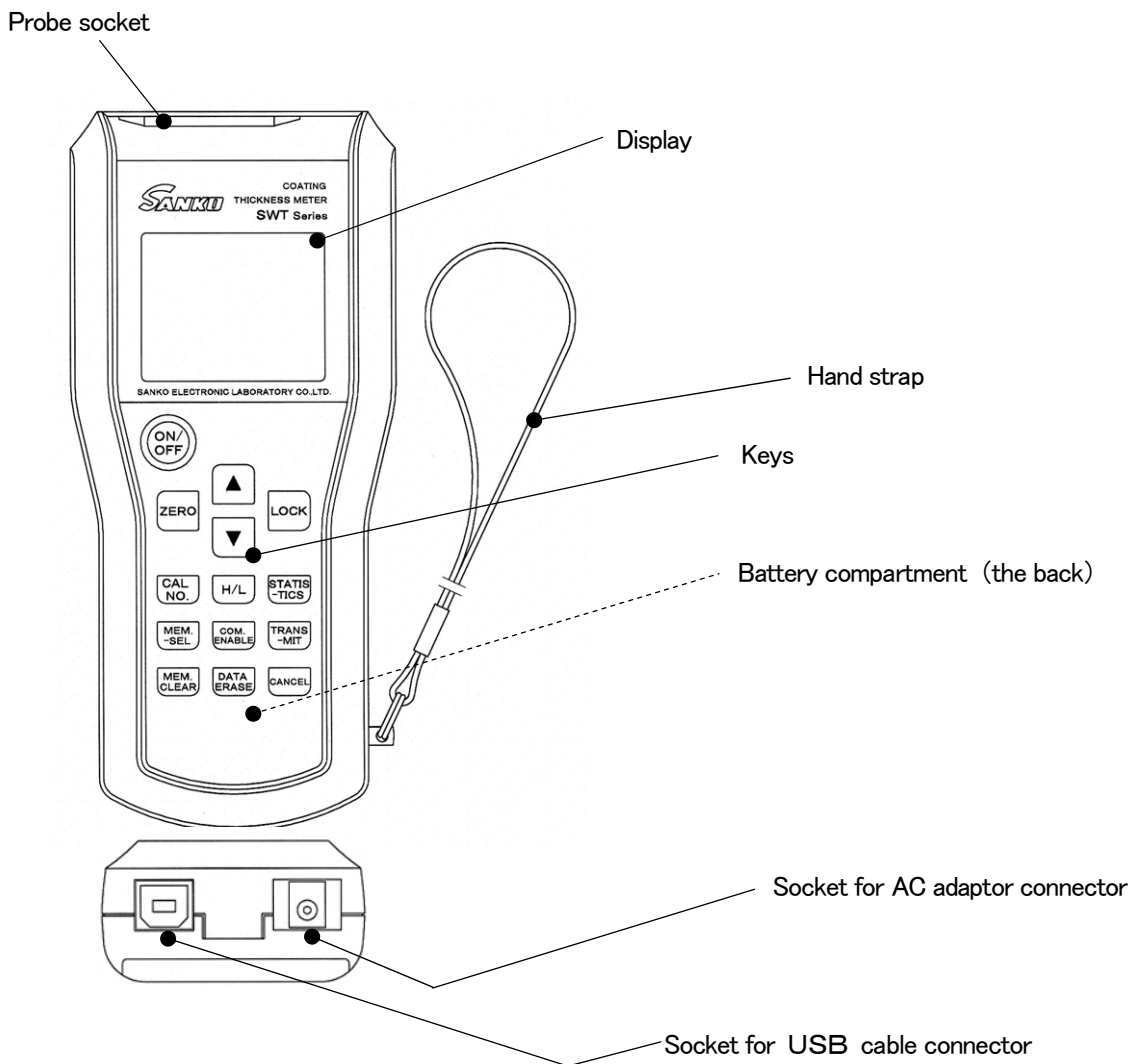

● Probe socket

Connect an optional-exclusive SWT probe to the probe socket.

- (1) To measure a film thickness of coated, plated, lining layer on substrates made of ferrous material please use a probe of (Fe) series for the connection.
- (2) To measure a film thickness of coated, plated, lining layer on substrates made of non-ferrous materials such as Aluminum, Copper, etc. please use a probe of (NFe) series for the connection

● Display

It indicates measurement results, operation guides, or malfunction status.

● Keys

- (1) Power On/Off key

It switches On or Off.

- (2) 「ZERO」key, 「▲」key, 「▼」key

They are adjusting keys to be pre-used before measuring to obtain correct results.

They are also used for adjustments when in high -function operations.

- (3) 「LOCK」key

It is a key to avoid erroneous operations caused by an inadvertent key entry.

- (4) 「Cal No.」key
It is a key to select calibration in high-function operations.
- (5) 「H/L」key
It is a key to set High/Low limit values in high-function operations.
- (6) 「STATISTICS」key
It is a key to process statistics of data stored in memory in high-function operations.
- (7) 「MeM.- SEL」key
It is a key to select memory to be used in high-function operations.
- (8) 「COM. ENABLE」key
It is a key to select for data transfer in high-function operations.
- (9) 「TRANSMIT」key
It is a key to activate transferring process of data in high-function operations.
- (10) 「MeM. CLEAR」key
It is a key to delete data stored in memory in high-function operations.
- (11) 「DATA ERASE」key
It is a key to erase one of data indicated on display in high-function operations.
- (12) 「CANCEL」key
It is a key to interrupt adjusting process and take an immediate step to measuring process in high-function operations

- Battery compartment
It contains 2 pieces of dry battery (R06P, AA).
- Hand strap
Hang the meter through a strap over your wrist never to drop it.
- Socket for AC adaptor
This is a socket connected to the exclusive AC adaptor (accessory).
- Socket for USB cable
It is a socket connected to a USB cable (accessory)

◆ Items indicated on LCD

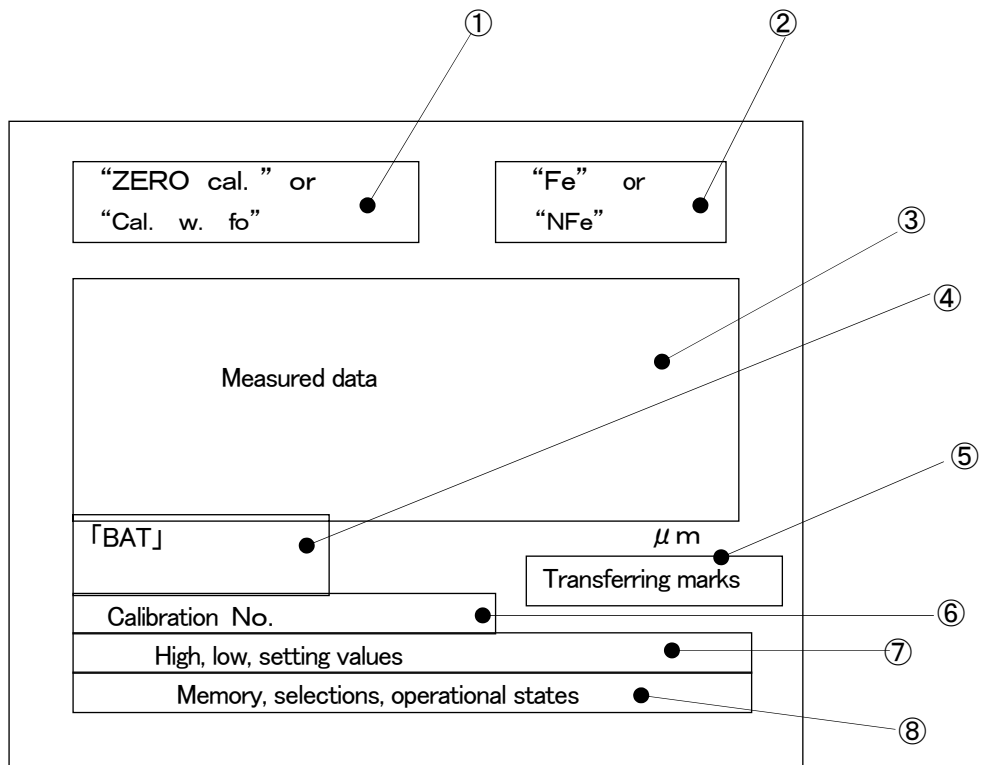

- ① Indicates 「ZERO cal.」 (Zeroing) or 「Cal.w.fo」 (Calibration Standard) when in process.
It never appears on the reading except when in process of these adjustments.
- ② Indicates 「Fe」 when a probe of Fe SWT exclusive series is in the connection, and 「NFe」 when a probe of NFe SWT exclusive series is in the connection.
- ③ Indicates a measured value upon pressing a probe.
- ④ 「BAT」 mark is indicated when battery has run out for replacement with 2 steps.
- ⑤ 「USB」 mark is indicated when data is transferred by USB to PC.
- ⑥ The number of calibration: stored in a pair of 「Zeroing」 and 「Calibration standard」 is indicated.
- ⑦ 「High limit value」、 「Low limit value」 is indicated when the limit value is set.
It flashes when a reading value exceeds beyond a setting limited value.
- ⑧ When selecting a memory place to store measurement data, the number of a memory place flashes.
When measuring while storing data into memory, the number of a storing place indicates.

◆ How to fit batteries

- ① Open the battery lid on the back of the unit.
Press down and slide the lid in direction of arrow to open.
- ② Insert batteries.
Ensure correct battery polarity \oplus 、 \ominus for placement.
- ③ Close the lid.



Caution

- Use designated and new (unused) batteries or ones supplied in this package.
- An incorrect use of batteries may cause leakages, bursts. Do not intermingle new ones with old ones.
- Take out batteries to store when not in use for a long absence, and that may avoid Leakages.
- Keep batteries off children and pets.
- Comply to the laws and rules in your Local Authorities when disposing of batteries.



When placing batteries in the unit, the messages and warning below on the screen may be indicated. And these are not breakdowns, wait until the reading disappears with a beeping sound.

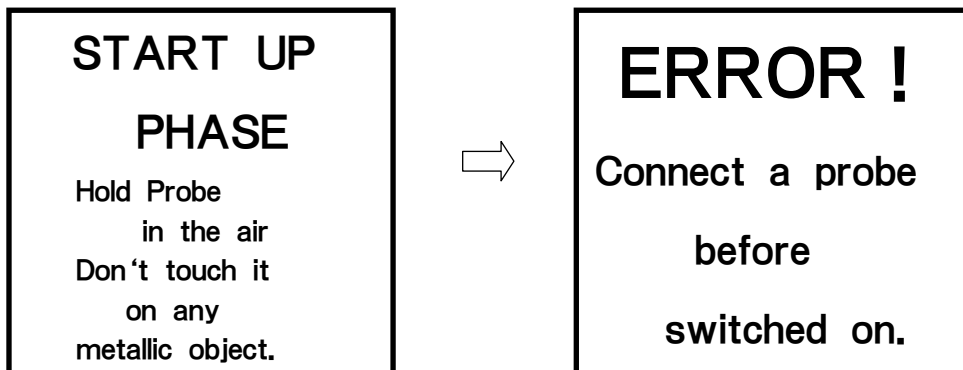

Batteries have run out when the display on the unit indicates the mark listed below. Replace with new batteries.

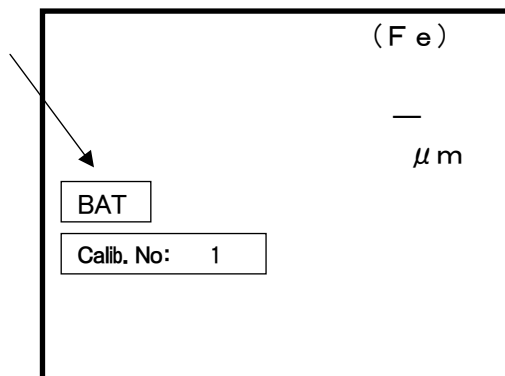

◆ How connect, disconnect probes

- ◎ Connect an optional, exclusive SWT probe to the main unit
Select one of the probes suited for your application.

Insert a probe connector into the probe socket of the main unit.

Make sure of aligning the keyway leading to a smooth joint without doing by force.

Insert it to the extent that it is locked.

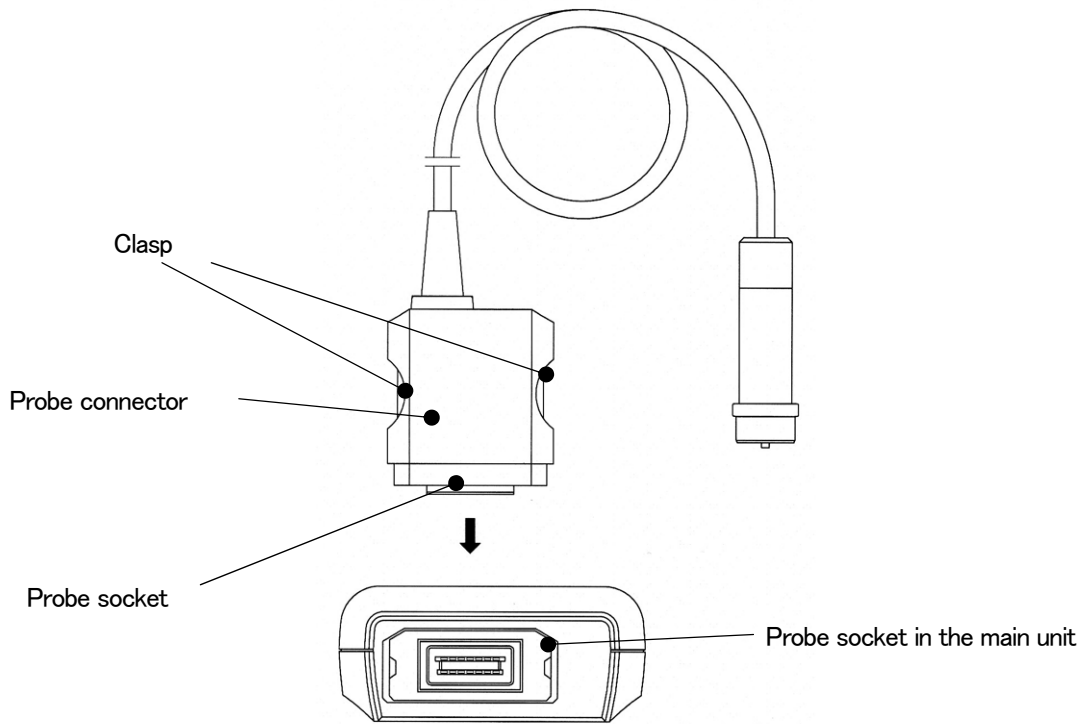

- ◎ Remove the exclusive probe from the unit.

Pull off the probe carefully by bending inward clasp springs at the both ends of the probe connector to release the clasps.

Do not pull off by force or it may cause damages.



Caution

Make sure that Power switches to off when connecting or disconnecting the exclusive SWT probes.

Or else, it may cause damages to connect or disconnect while Power is on.

◆ How to hold probes

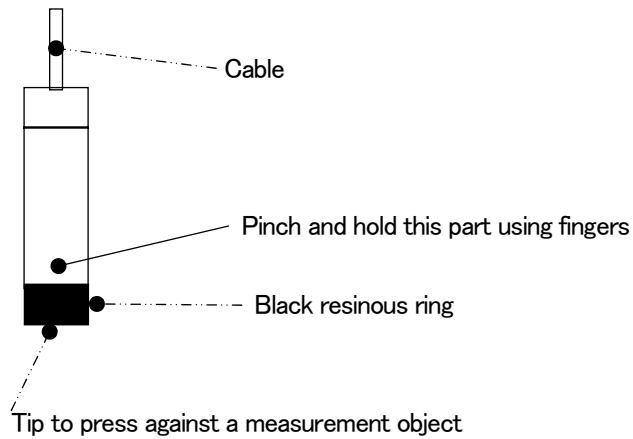

◆ How to press a probe to an object

- Keep the probe 5 cm or over away off metallic objects when not in use of measuring.
- Press the tip of the probe perpendicularly against a measurement object.
Tilting may cause large errors.

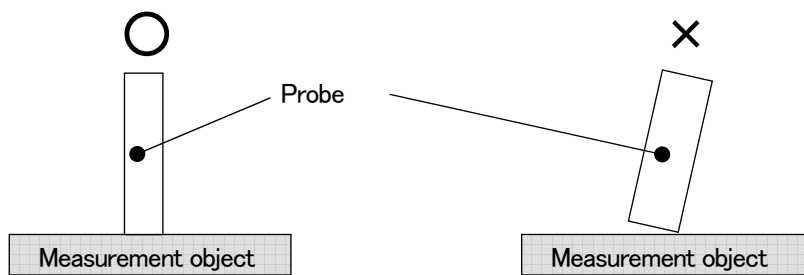

- ※ Press the probe quickly and smoothly to objects.
A slow-acting press may cause large errors.



Caution

- ◆ Do not smash or hit the probe against objects, or it may cause damages to probes and to objects
- ◆ Do not scrape, scrub objects with the probe except in a special measurement.
Or it may break the tip of the probe and cause damages to the tip and surface of objects

How to operate

(1) How to switch Power source

Press **ON/OFF** key.

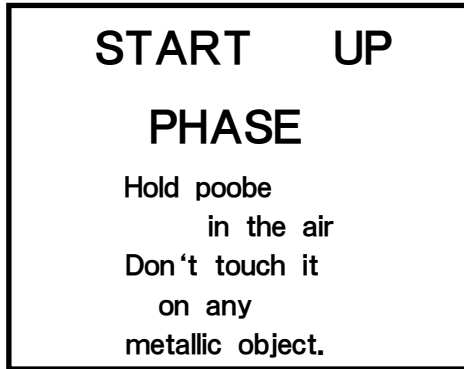

This message lasts for about 5 seconds.



Caution

Hold the probe in air without operation when the reading is on display. Or it may indicate 「ERROR」 and automatically switch off Power.



The buzzer emits a beeping sound.

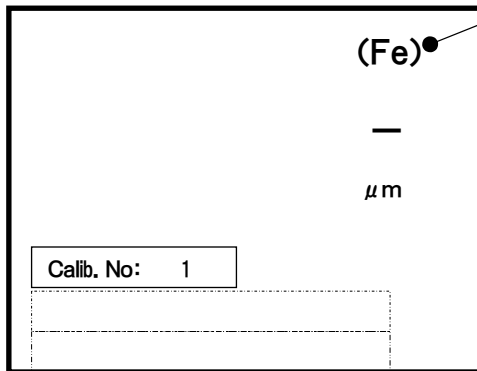

「Fe」shows that a SWT exclusive probe in Fe series is connected and set for Ferrous substrate measurements

The display shows that it becomes possible to take measuring and adjusting procedures of this unit.



Caution

Never remove probe from a unit when Power is On. Or the electric shocks may damage the probe and the unit

Note: 「Calib. No: —」
↑

A number 「1」 is indicated at the first opening of the unit, and from then on the last set entry is indicated everytime it is operated.

And, when 「High limit value」、 「Low limit value」 is set, or when memory is used, the setting values and Nos. are indicated on each column (chained lined sections).

(2) How to switch off

Press **ON/OFF** key.

The buzzer beeps, beeps. (twice)

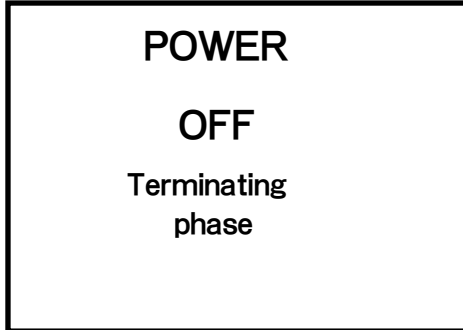

The message lasts for about 5 seconds.



This unit switched off.

(3) How to select 「Calibration No: 」

It is capable of getting started on measurements immediately after it becomes possible to take measurements and adjusting by switching Power to ON as described on page 12. However, it makes errors depending on material formation and shapes to be measured. To minimize measurement errors and obtain as accurate results as possible please be sure of carrying out 2 points adjustments of 「Zeroing」 and 「Calibration standard」 before measuring process.

SWT-7200 is capable of storing 10 sets of calibration data.

The storing place is indicated by a calibration No.

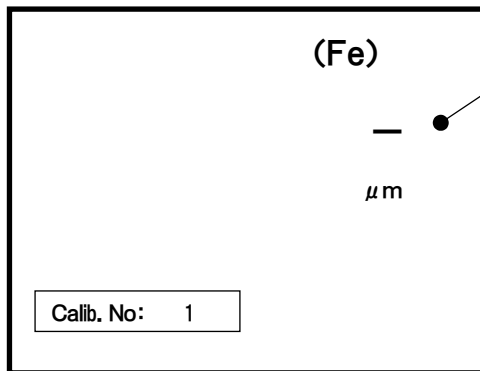

「NFe」 is indicated when a SWT exclusive probe in NFe series is connected.



Press key.
The buzzer emits a beeping sound.

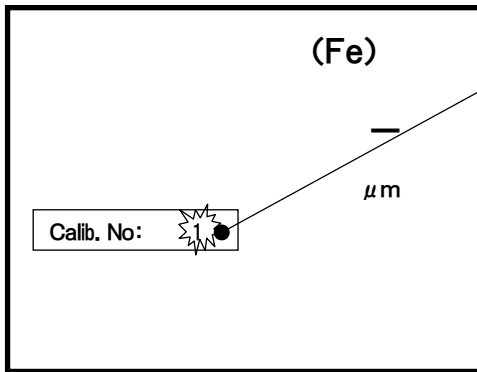

A number on the display flashes.



Caution

The number flashes for about 10 seconds. Press or key during the period of 10 seconds flashing. Otherwise the buzzer beeps, beeps to return automatically to the beginning. Try again to reselect the number from the beginning.

Press key or key to select your desired number.



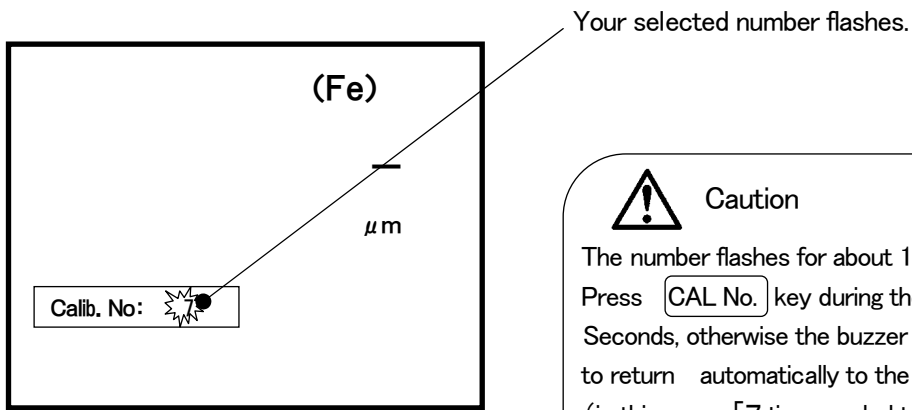

Caution

The number flashes for about 10 seconds. Press **CAL No.** key during the period of 10 Seconds, otherwise the buzzer beeps, beeps to return automatically to the beginning. (in this case, 「7」is canceled to return automatically to 「1」). Try again to reselect from beginning.



Press **CAL No.** key.
The buzzer beeps.

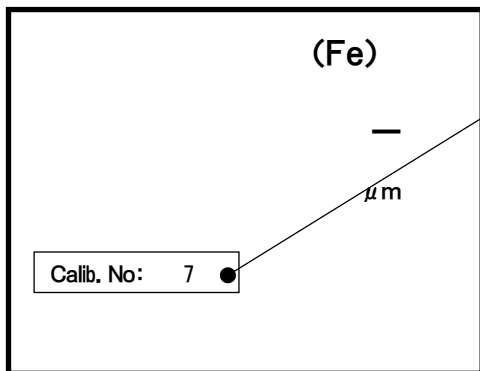

The flashing stops
「Calibration No. 7」 is selected and fixed.

It is capable of getting started on measurements after it becomes possible to take measurements and adjusting by selecting 「Calibration No. 7」.

However, it makes errors depending on material formation and shapes to be measured. To minimize measurement errors and obtain as accurate results as possible please be sure of carrying out 2 kinds of adjustments of 「Zeroing」 and 「Calibration standard」 before measuring process.

(4) Zeroing

It is capable of getting started on measurements immediately after the message of 「START UP PHASE」 has disappeared as described on page 12.

However, it makes errors depending on material formation and shapes to be measured. To minimize measurement errors and obtain as accurate results as possible please be sure of carrying out 2 points of adjustments of 「Zeroing」 and 「Calibration standard」 before measuring process.

※ Please prepare for a Substrate plate the identical material, quality and size to a measuring object.
(This substrate plate should be designated as a 「Zero Plate」)

Press **ZERO** key.

The buzzer emits a beep sound.

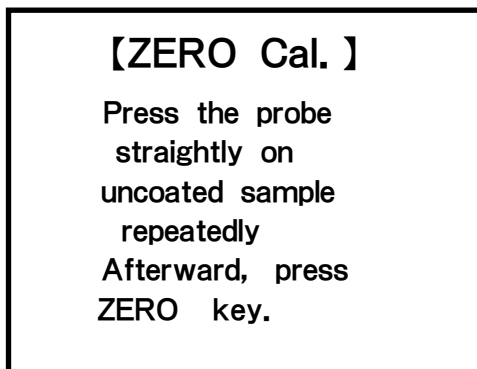

Press the probe on the above 「Zero Plate」 when the message is indicated on display (about 10 second).



The buzzer beeps.

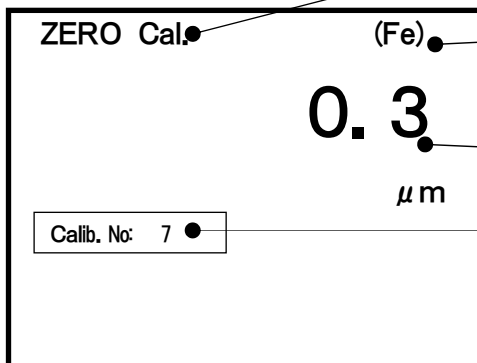

Zeroing is in process.

The reading shows that the unit is set to measure on substrate material of Ferrous by connecting a probe of the 「Fe」series.

Measured numerical value

「Calibration No. 7」 to store values of 「Zeroing」 and 「Calibration standard」



Remove the probe from 「Zero plate」



Press **ZERO** key.

The buzzer beeps.



- Repeat measuring processes, 2~10 times by pressing the probe to 「Zero plate」. (A measurement value is displayed whenever a probe is pressed)
- ◆ When a measuring process reaches the 10th time, the buzzer beeps and zeroing automatically finishes without pressing **ZERO** key.

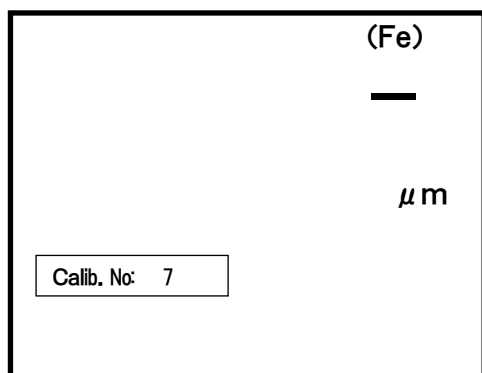

The reading shows that 「Zeroing」 has completed and it becomes possible to take measuring and adjusting operations of this unit.



- It is correct that numerical values measured by pressing the probe to the 「Zero Plate」 indicates 「0」 or in the neighborhood of 「0」.
When the measured value results in largely off 「0」 μm, please try again zeroing from the beginning.
- [LLL] indicated on display during a time of zeroing means that the calibration point heavily deviates from the standard please make sure that the material is not in process of being built with others and repeat the zeroing in 2~4 times until a stable 「0」 is obtained.



Caution

The message of 「ZERO Cal.」 described on the previous page is indicated on display for about 10 seconds. Without pressing the probe to the 「Zero Plate」 during the period of the reading on display, it automatically returns to the beginning. Try again zeroing procedures from the beginning if necessary.

(5) Zeroing in special cases (Multi-layers)

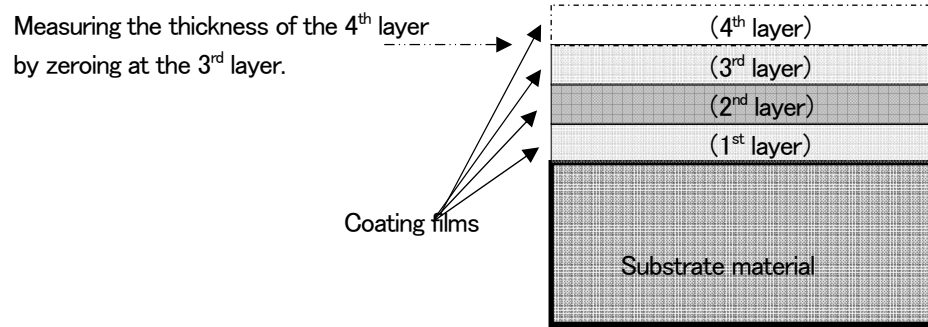

◎ In case of being painted as shown with multi-layers on the substrate there may be needs to measure thicknesses of each layer. For example, measuring only the thickness of the 4th layer please zero as an assumed ZERO at the surface of the 3rd layer stacked on the substrate.

◎ When zeroing again on the substrate after having finished the above measurements and if the combined thickness of 3 coating layers from 1st to 3rd exceeds 50 μ m, please zero the meter on the following procedures. If the thickness of 3 combined layers is below 50 μ m, take the same procedure as usual zeroing to release.

- ※ Prepare the identical material quality, plate size to a measuring object.
(This is a designated as a Zero Plate)

Press ZERO key.

The buzzer emits a beeping sound.



【ZERO Cal.】
 Press the probe
 straightly on
 uncoated sample
 repeatedly
 Afterward, press
 ZERO key.

Press the probe on the above 「Zero Plate」 while the message is indicated on display.



The buzzer beeps, beeps, beeps.



ZERO position is
OFFSET.

To continue ZERO
adjustment, press
ZERO key twice
successively.

Press **ZERO** key twice while this message
on the reading

 **Caution**

This message is indicated on display for about
10 seconds. If no ZERO key is pressed when
the reading is on display, 「Zeroing」 is
automatically interrupted and returns to the
beginning of the process Try again
zeroing from the beginning if necessary.

↓

Press **ZERO** key . -- ①
The buzzer beeps.

↓

Press **ZERO** key. -- ②
The buzzer beeps.

[ZERO Cal.]

Press the probe
straightly on
uncoated sample
repeatedly
Afterward, press
ZERO key.

Press the probe to 「Zero Plate」 when on the reading for
10 seconds.

↓

The buzzer beeps.

↓

(ZERO Cal. ●) (Fe)
0.3
μm

Calib. No: 7

The reading shows that it is process of zeroing
adjustments

Measured numerical value

- Repeat measuring processes, 2~10 times by pressing
the probe to 「Zero plate」.
(A measurement value is displayed whenever a probe is
pressed)
- ◆ When a measuring process reaches the 10th time, the
buzzer beeps and zeroing automatically finishes without
pressing **ZERO** key.

Remove the probe from 「Zero Plate」.



Press **ZERO** key.

The buzzer beeps.

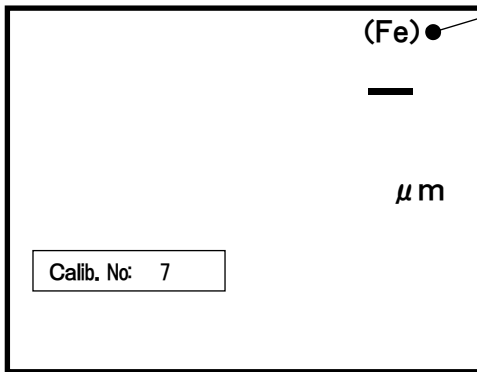

When a SWT exclusive probe in the NFe series is connected, (NFe) is indicated on the reading.

「Zeroing」 has completed and it becomes possible to take measuring and adjusting operations of this unit.





- It is correct that numerical values measured by pressing the probe to the 「Zero Plate」 indicates 「0」 or in the neighborhood of 「0」.
When the measured value results in largely off 「0」 μm , please try again zeroing from the beginning.
- [LLL] indicated on display during a time of zeroing means that the calibration point heavily deviates from the standard please make sure that the material is not in process of being built with others and repeat the zeroing in 2~4 times until a stable 「0」 is obtained.

Note:

The latest measured value replaces the previous one and the new value of 「Zeroing」 is stored.

(6) Calibration standard (CAL)

- Prepare 「Zero Plate」 used in 「Zeroing」.
- Prepare 「Thickness Standard」 which thicknesses is thicker or as thick as a measuring film.
- Place 「Thickness Standard」 on 「Zero Plate」.
- Press  key or  key.

The buzzer emits a beeping sound.

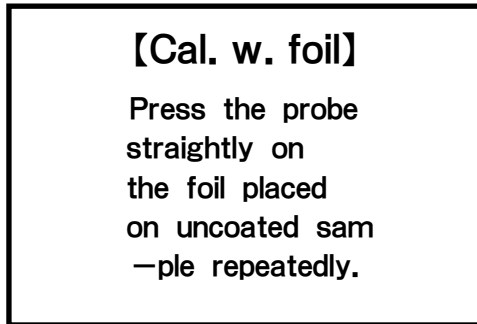

Press the probe on the 「Thickness Standard」 stacked on the 「Zero Plate」 when this message is displayed on the reading. (for about 10 seconds)



The buzzer beeps whenever the probe is pressed.

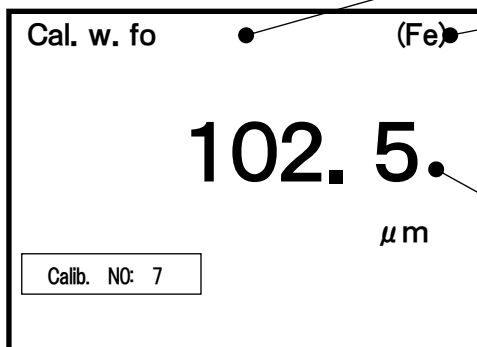

The reading shows that it is in process of Calibration standard.

The reading shows that the unit is set to measure on the substrate material of Ferrous by connecting a probe of the 「Fe」 series.

Measured numerical value



Remove the probe from 「Thickness standard」.



In about 5 seconds the buzzer beeps, beeps.





- Repeat measuring operations, 2~10 times by pressing probe to 「Thickness standard」 on the 「Zero plate」. (The measured value is indicated whenever the probe is pressed.)
- ◆ When the measuring process reaches the 10th time, the buzzer beeps to take the next page screen.
- Wait for while (about 5 seconds) after the following procedures completed.





Caution

The message of 「Cal. w. foil」 is indicated on the reading for about 10 seconds. Without pressing the probe during the period of the reading, it automatically returns to the beginning. Try again Calibration standard procedures from the beginning if necessary.

【Cal. w. foil】



Use   key,
adjust displayed
value to
the thickness
of foil.

When the reading message is indicated on display
(about 5 seconds), press  key or  key
to equate a thickness value with
「Thickness Standard」 value.





Caution

The message is indicated on the reading for about
5 seconds.

If no  key or  pressed during this time,
the unit automatically interrupts 「Calibration Standard」
and returns to beginning.

Try again 「Calibration Standard」from the beginning
if necessary.



A press of  key or  key beeps
the buzzer and indicates the latest value pressed
by probe.

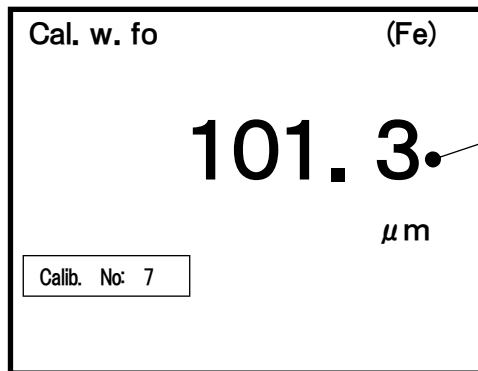

Numerical value by the latest press of a probe.



As example, equate a value on the reading with the thickness
of Thickness standard by pressing  key (tentatively 100 μm)

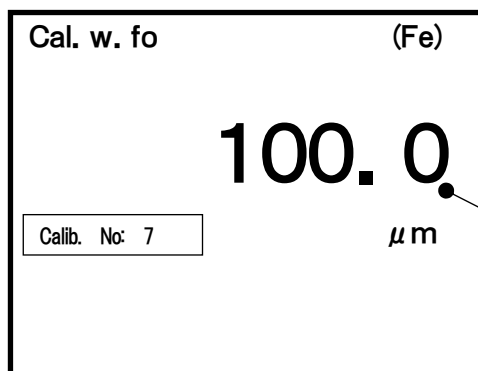

A press of  key increases the displayed value.

A press of  key decreases the displayed value.

Equate value with the Thickness Standard value.



Waite for about 5 seconds after the numerical value equated
with the Thickness Standard.

The buzzer beeps, beeps.

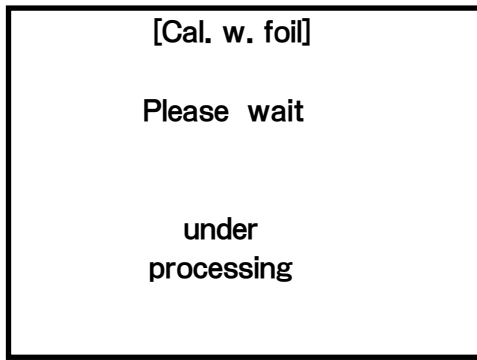

The buzzer beeps, beeps.

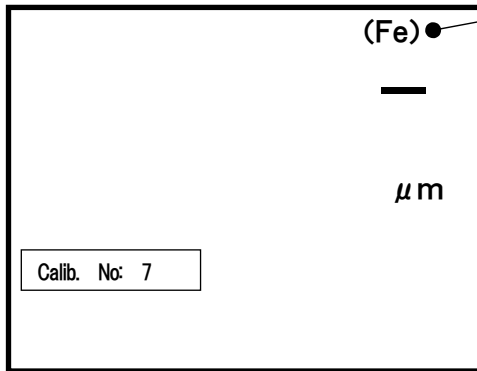

When a SWT exclusive probe in the NFe series is connected, (NFe) is indicated on the reading.

It becomes possible to take measurement and adjusting operations.



- It is correct that numerical values measured by pressing the probe to the 「Thickness Standard」 on the 「Zero Plate」 indicates the neighborhood of 「Thickness standard」.
- When the measured value results in largely off the thickness of 「Thickness Standard」 please try again calibration standard from the beginning.

Note:

The latest measured value replaces the previous one and the new value of 「Calibration standard」 is stored.

(7) How to delete calibration

Take the following procedures to delete calibration when the reading on the screen is locked or after batteries replaced or when it becomes impossible to process 「Zeroing」, 「Calibration Standard」(CAL).

- Select 「Calibration NO. 」 storing 「Zeroing value」 and 「Calibration standard value」 to be deleted.
Refer to page 14 on how to select 「Calibration No: 」.

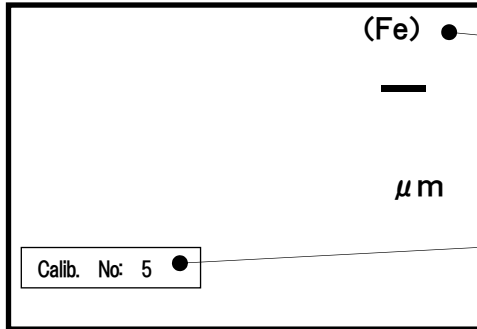

When a SWT exclusive probe in the NFe series is connected, (NFe) is indicated on the reading.

「Calibration No. 」 storing values of 「Zeroing」 and 「CAL」 to be deleted.

When holding key, press key.
The buzzer beeps, beeps.

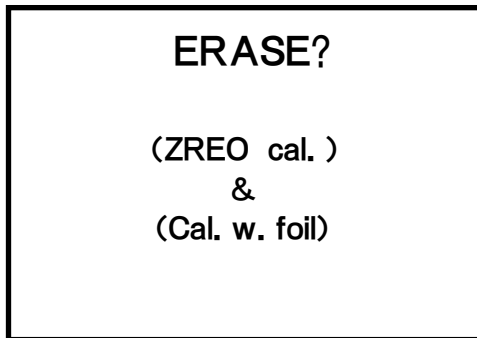

When this message is indicated on the reading, press key. (for about 5 seconds)



Caution

This message is indicated for about 5 seconds. If no key is pressed during the time of 5 seconds, the unit interrupts deleting and returns to the beginning. Try again from the beginning if deleting is necessary.

The buzzer beeps, beeps.

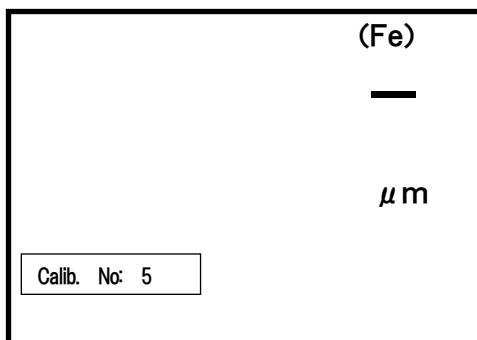
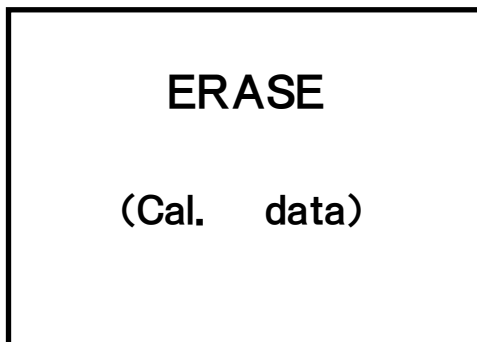

It becomes possible to take measurements and adjustments procedures of this unit.

After deleting, take 「Zeroing」, 「Calibration standard」 procedures proceeding to measuring.

Function switching

(1) Switching to Non-Interrupt Measurement Mode

Switch to 「non-interrupt measurement mode」 when it is necessary to slide a probe along the measuring surface of a substrate as illustrated on the right figure for continuous measurements of films.

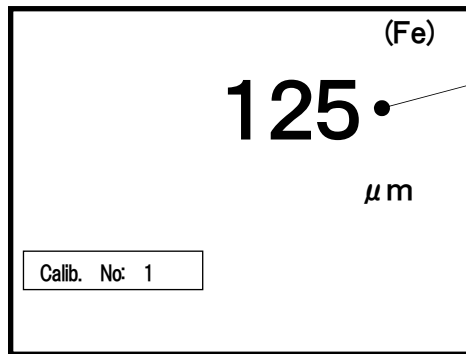
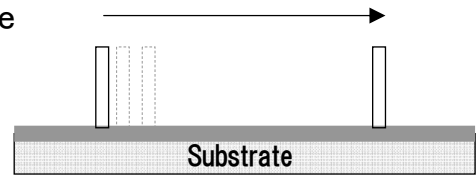

A measuring value is indicated and stored each time a probe is pressed in a normal state.

Hold **ZERO** key and press **▲** key.

The buzzer beeps, beeps.



This unit has turned into 「non-interrupt measurement mode」. Measurements can be made about in 0.5 seconds intervals and the data is indicated with a beeping sound.

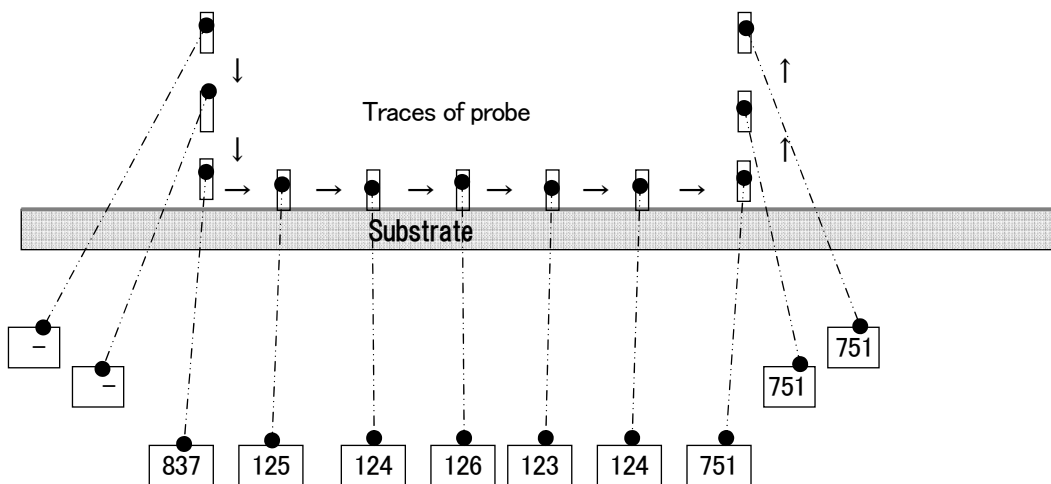

Measuring values on display (indicated successively each 0.5 seconds interval) →

- ※ The non-interrupt function is stored when switching Power to OFF, and can be maintained until re-activating to switch to ON.



Caution

Note that this measuring method may damage the measuring surface or the probe tip due to sliding frictions. Please try fewer to take this method to minimize the frictions.

《Returning to the beginning》

To return 「non-interrupt measurement mode」 to the beginning take the same procedures as at the initial setting.

Hold **ZERO** key and press **▲** key.

The buzzer beeps, beeps.



「non-interrupt measurement mode」 has been released and returned to the beginning.

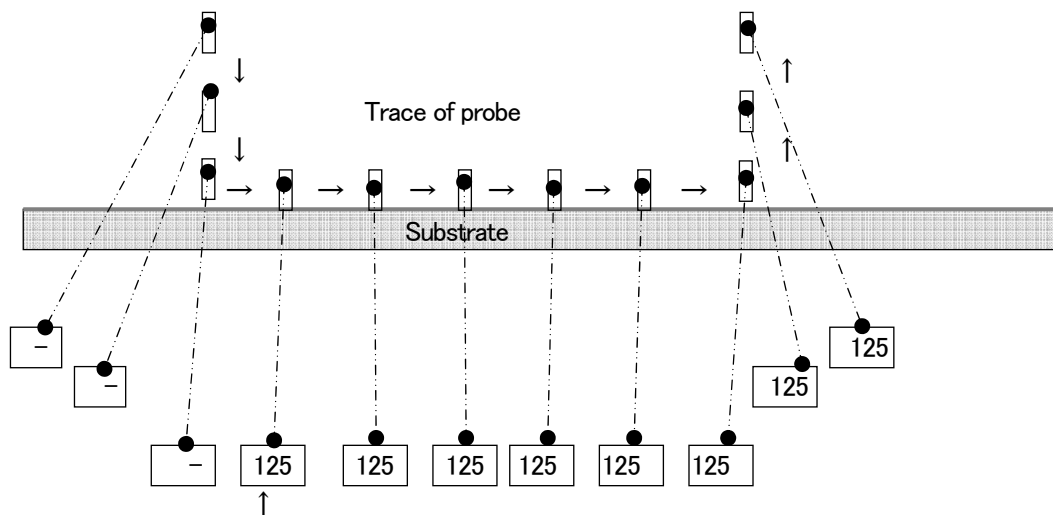

Measured values are stored until a next measurement is taken.

(2) Switching to Resolution

To inspect precisely a thickness up to $500\ \mu\text{m}$ it is possible to take solution measurements by switching to a $0.1\ \mu\text{m}$ ($0\sim 400\ \mu\text{m}$) unit, to a $0.5\ \mu\text{m}$ ($400\sim 500\ \mu\text{m}$) unit. In this case it changes resolution units by taking the following procedures.

- Switch Power to Off.
- Hold **LOCK** key and press **ON/OFF** key until the buzzer beeps in the following.

The buzzer beeps, beeps.

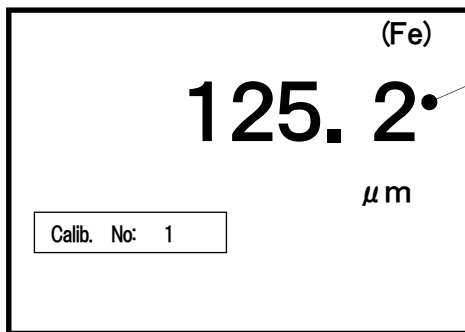

Indicated :

$0\sim 400\ \mu\text{m}$ by the $0.1\ \mu\text{m}$ unit,
 $400\ \mu\text{m}\sim 500\ \mu\text{m}$ by the $0.5\ \mu\text{m}$ unit.

《Returning to the beginning》

To return [0.1 μm] display resolution to the beginning take the same procedures as the above.

- Switch power to OFF.
- Hold **LOCK** key and press **ON/OFF** key until the buzzer beeps in the following.

The buzzer beeps, beeps.

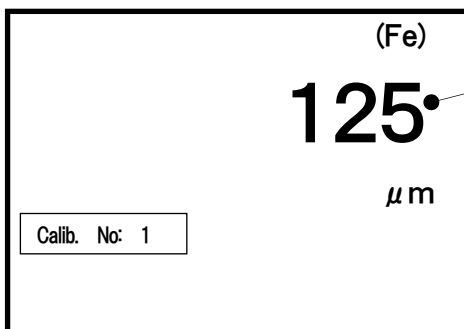

No indication under a decimal point

(3) Switching to Key Lock Mode

This is to prevent this unit from making errors by inadvertently fingering a key in taking measures.

- Press **LOCK** key when Power is On.
The buzzer beeps.

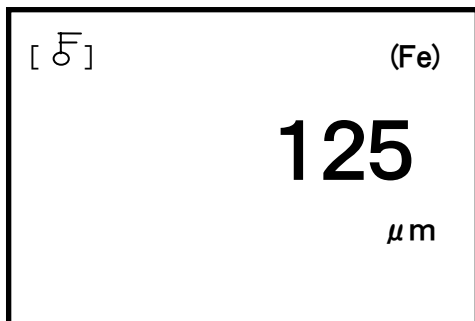

Any presses of keys except **ON/OFF** key locks the operation to be non-operational to avoid errors.

《Releasing lock》

- Press **ON/OFF** key and switch Power off.
- Press **ON/OFF** key and switch Power on.
The lock has been released and all keys can be activated.

Measuring

- According to explanations on page 11 hold a probe and quickly press it to a measuring object.

The buzzer beeps.

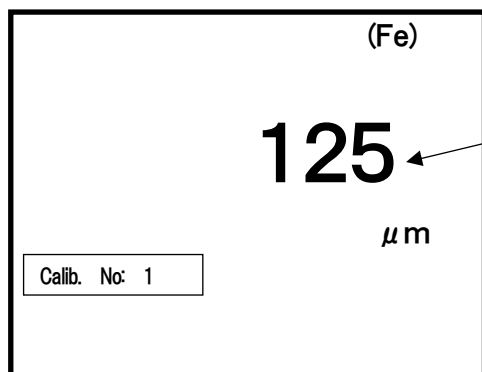

A measured result is indicated.

Each time a probe is pressed to an object the buzzer beeps and the measuring result is indicated.

《Auto-Power-OFF》

Power will automatically be switched off 3 minutes after the last entry to save batteries.

The buzzer beeps.

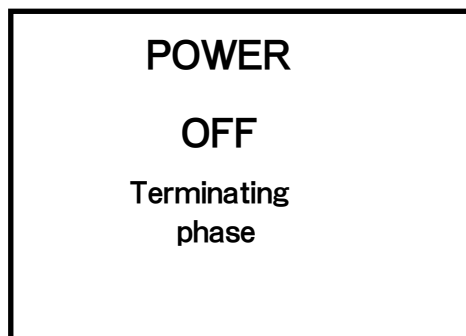

The message lasts for about 5 seconds.



The buzzer beeps.

This unit switches Power off.

- ※ SWT-7200 equips AC-adaptor as one of accessories. And Auto-Power-Off functions also works with AC-adaptor connected.

Setting high/low limits value

To judge quickly if the coated film thickness of a product stays within a range of thicknesses corresponding to management standards and controls, it is necessary to set high/low limits beforehand and if the numerical value on display exceeds the limits, the number flashes and emits a warning sound.

Note: A 「CalibrationNo. 」 corresponds to a set of both limits values for setting

(1) Setting a High Limit value

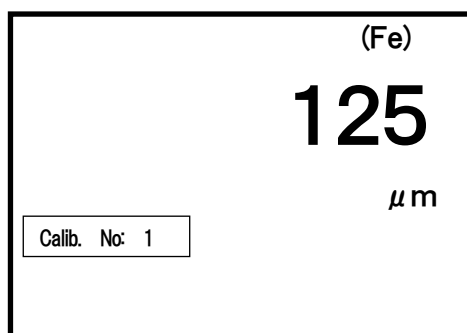

Press **H/L** key.
The buzzer beeps.

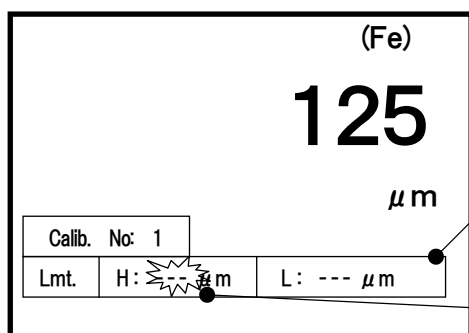

A setting column for high/low limits is indicated

A high limit column flashes.



Press **▲** key to equate with a necessary value

If the number exceeds, press **▼** key to decrease numbers for equating.



Caution

A high limit column flashes for about 10 seconds. Press **▲** key during this 10 seconds, or the setting column for high/low limits disappears and returns automatically to the beginning. In this case try again the limit setting from the beginning

Press **H/L** key.

Note: When no high limit is needed, press **H/L** key without pressing **▲**

The buzzer beeps.

「H: --- μm 」 stops flashing

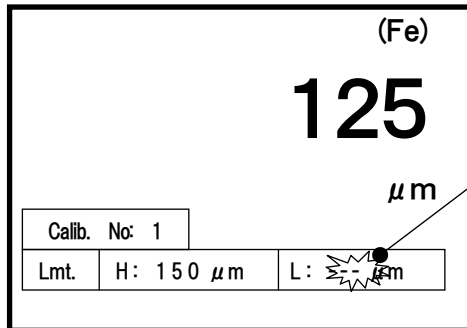

A low limit value setting column flashes.

When no low limit setting is necessary, press **H/L** key without pressing **▲** key.

And then the buzzer beeps and the unit returns to measurement and adjustment of this unit procedures.

When a low limit setting is necessary, take the following operation without pressing **H/L** key.

(2) Setting a Low Limit value (following a high limit value)

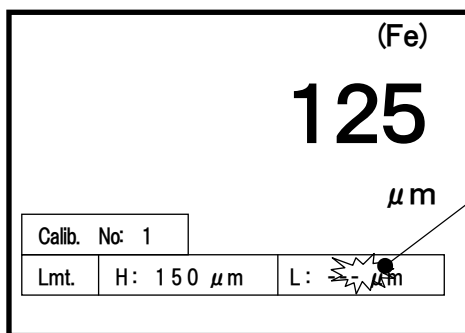

A low limit value setting column flashes.



Caution

A low limit value flashes for about 10 seconds. Press **▲** key during this 10 seconds, or a low limit setting interrupts and 「L: --- μm 」 stops flashing and automatically returns to the beginning. When a low limit setting is necessary, press twice **H/L** key to make a screen as the above left figure.

Press **▲** key to equate with a necessary value.
If the number exceeds, press **▼** key to decrease for equating.

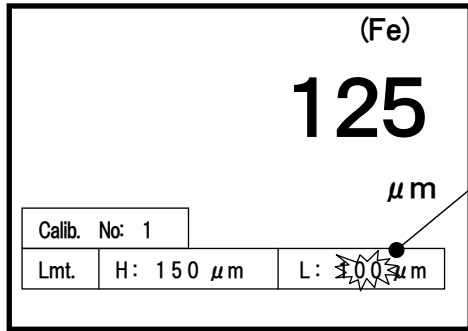

A low limit value setting column flashes.



Press key.
The buzzer beeps.

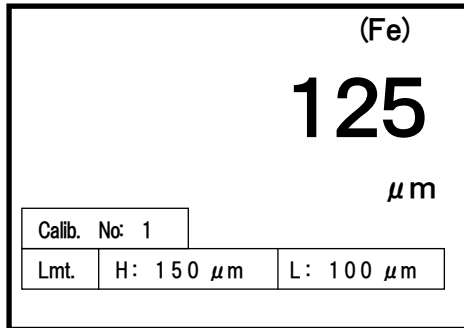

Limit values are set and it has return possible to measure and adjust this unit.

(3) Deleting a set limit value.

Select a 「Calibration No: 」 storing limit values to be deleted.
Refer to (How to select 「calibration No: 」) on page 14.

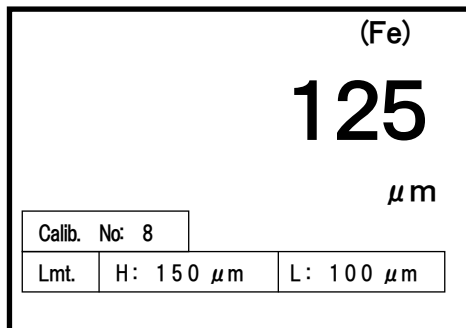

Hold **H/L** key and press **DATA ERASE** key.

The buzzer beeps, beeps.

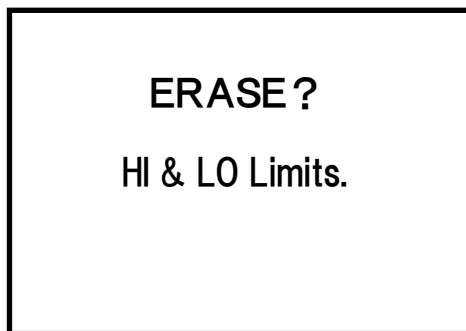

Press **DATA ERASE** key.
The buzzer beeps, beeps.

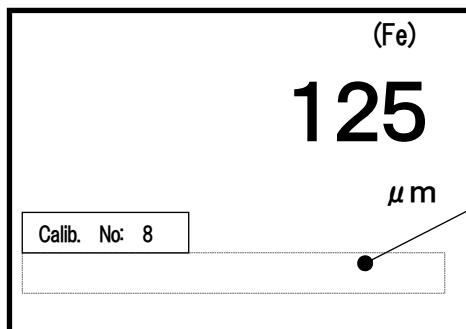

Caution

The message of deletion is indicated for 10 sec.
Press **DATA ERASE** during a time of 10 sec.
Or data is not erased and returns automatically
to the beginning. Try again from the beginning
to delete the limit value.

Measurements with High - Low limit values

1) Within a range of limit values

The buzzer beeps.

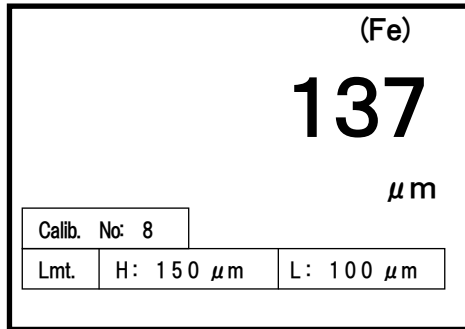

(2) When a measured value goes over a high limit value

The buzzer beeps.

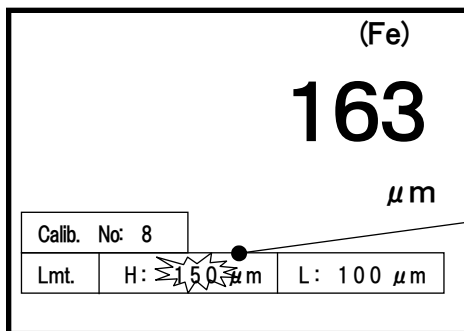

A high limit setting value flashes.

(3) When a measured value goes under a low limit value.

The buzzer beeps.

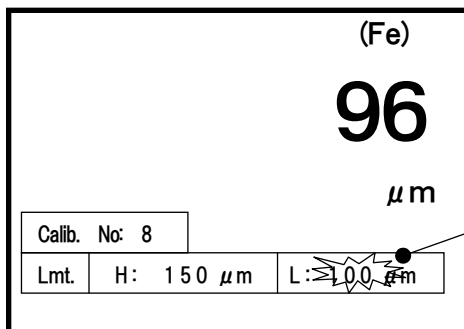

A low limit setting value flashes.

Storing measured values

SWT-7200 stores Max.10, 000 data.

Places to store are listed as below.

Sections: A section stores 10 data. There are numbers indicated in each 「Places to store data」

Blocks: A block contains 10 「Sections」. Each section has each independent number.

Groups : A group contains 20 「Blocks」. Each block has each independent number.

SWT-7200 has 5 「Groups」.

The relating indications are as follows.

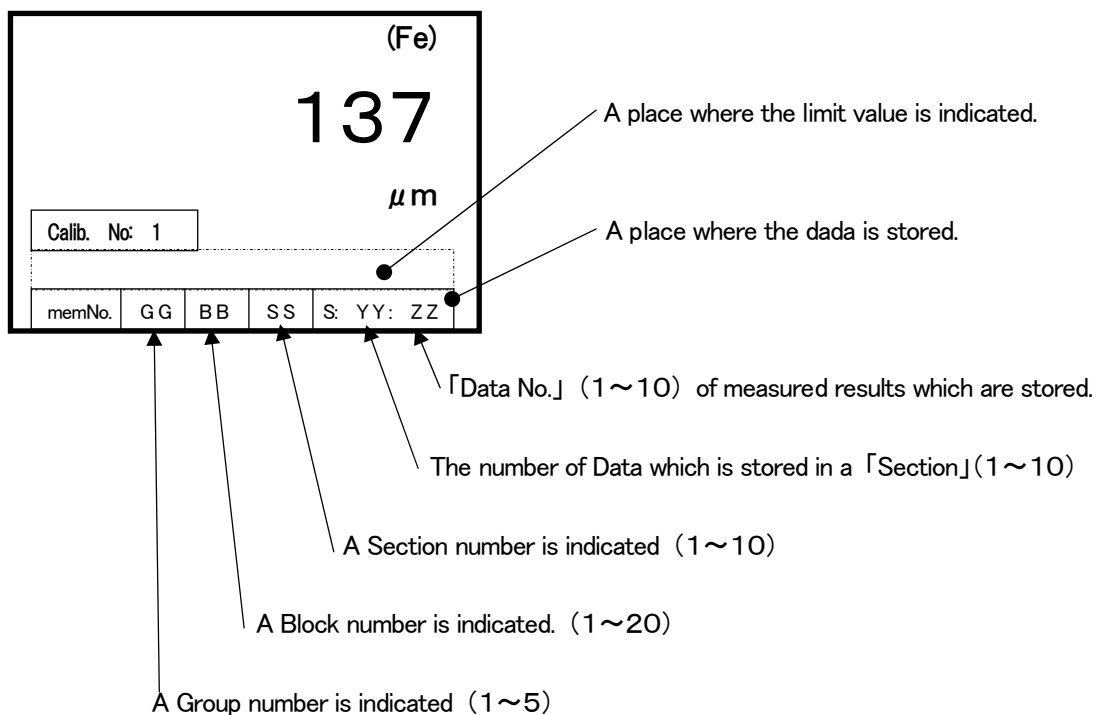

Note: the above numbers are as follow when delivered to users.

mem No.	1	1	1	s: 10 :	1
---------	---	---	---	---------	---

(1) How to select a data storing place

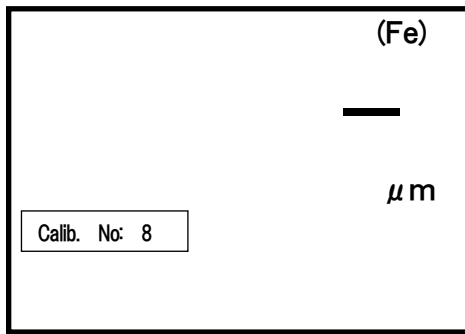

For this example :

A setting is made when storing data from the following

Group number: 「3」

Block number: 「12」

Section number: 「1」

And a storing number per section is set at 「8」.

Press **MEM.-SEL** key.

The buzzer beeps.

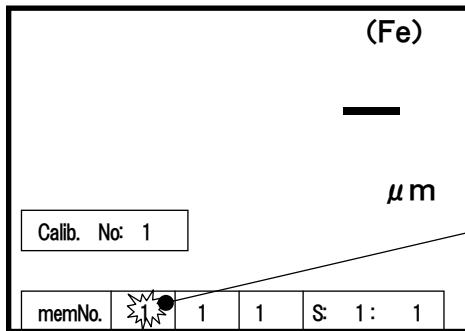

Note: The Figure on the left shows numbers when this unit is delivered.

Flashes

Press **▲** key, or **▼** key.
Select a Group No. 「3」.

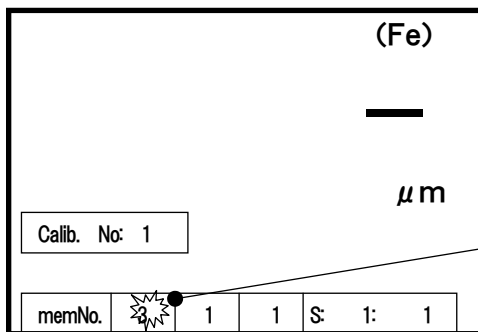

Flashes.



Caution

A memory number flashes for about 10 sec.

Press **MEM.-SEL** key otherwise the flashing interrupts and the previous indicated value remains set, returning to 「Ready to measurements and adjustments」 Try again from the beginning if necessary to change a group number.

Press **MEM.-SEL** key.

The buzzer beeps.



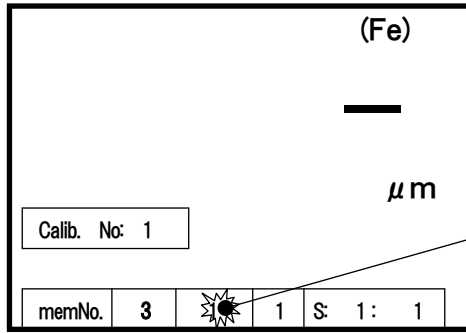

A group No.「3」 is set.
Then moving on to setting a Block No.

Flashes.

Press  key or  key to select a Block No.「12」.

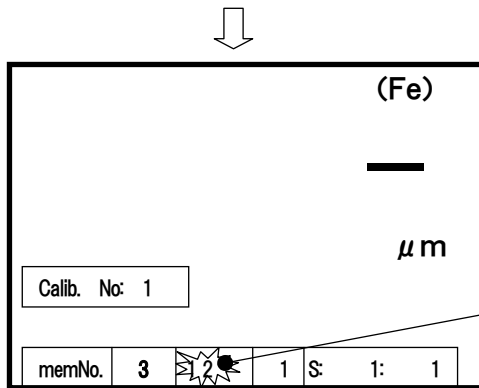

Flashes.

Press  key.

The buzzer beeps.

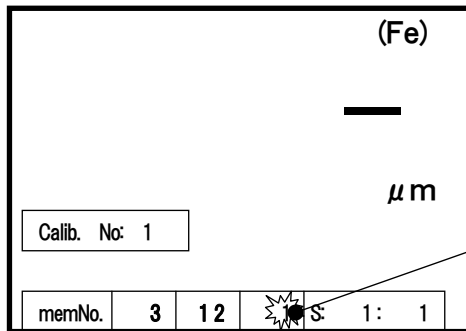

A Block No.「12」 is set.
Then moving on to setting a Section No.

Flashes.

Press  key or  key to select a Section No.「1」.

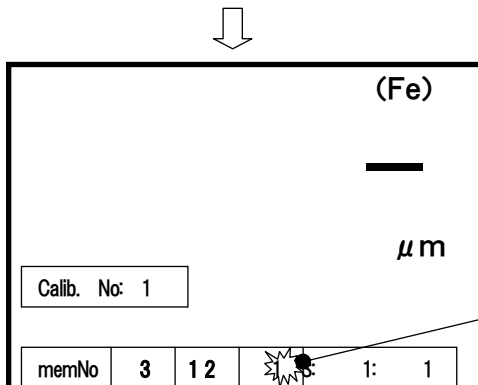

Flashes

Press **MEM.-SEL** key.
The buzzer beeps.

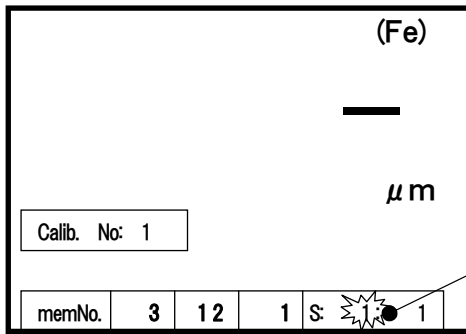

A Section No.「1」 is set.
Then moving on to setting a storing number
in one section.

Flashes.

Press **▲** key or **▼** key to select a storing number 「8」.

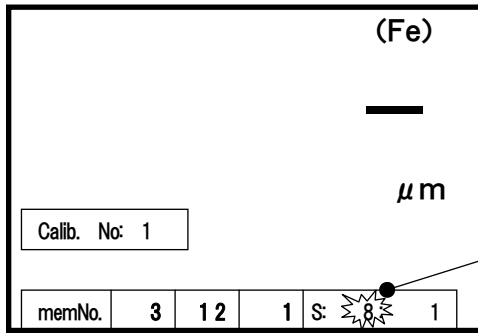

Flashes

Press **MEM.-SEL** key.
The buzzer beeps.

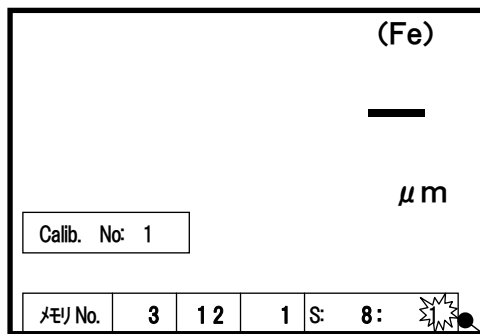

Designate the first storing place in a 「First
Section to store」 for data storing with a number.

For this example, designate to start storing from
「the first (1) in Section」.

Flashes

Press **▲** key or **▼** key to
select the first storing place 「1」.



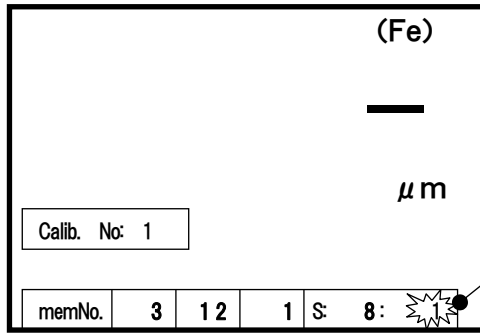

Flashes

※ Note

Pressing twice **MEM.-SEL** key turns the screen to a stage of 「Data is not stored」 and then 「Data storing place」 disappears on the screen.

To store measured data press **MEM.-SEL** key 6 times successively and 「Data storing place」 as Fig. on the left is displayed. And make sure that any numbers on the screen do not flash.

「Setting a data storing place」has completed and it becomes possible to take「Measurements and adjustments」procedures.

Press **MEM.-SEL** key.※
The buzzer beeps.

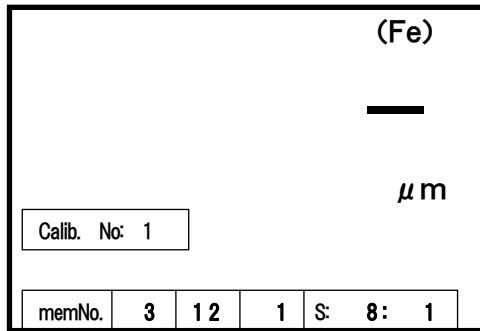

(2) How to keep data from being stored

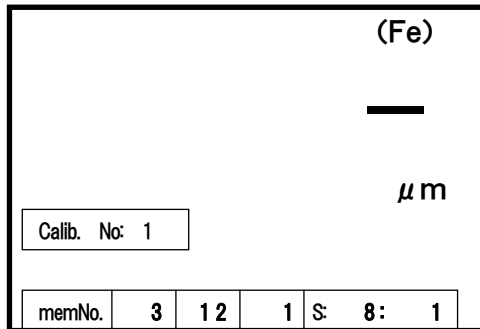

The screen is on the stage of 「Data is stored」.

Press **MEM.-SEL** key.
The buzzer beeps.

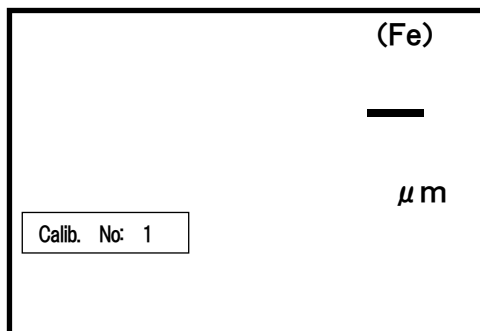

The screen turns to a stage of 「Data is not stored」.

Measurements in storing data

- Prepare this unit for measuring in storing data with 「Data is stored」 on the screen.

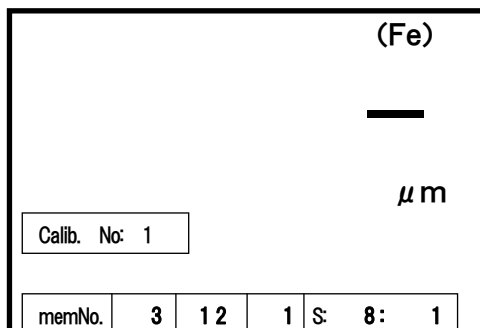

Measured data are stored in the following steps:
Data are stored in order into a 「Group No. : 3」,
a 「Block No.: 12」, a 「Section No.: 1」 and
a 「Data No.: 1」

- According to explanations on page 11, hold and quickly press a probe to a measuring object

The buzzer beeps.

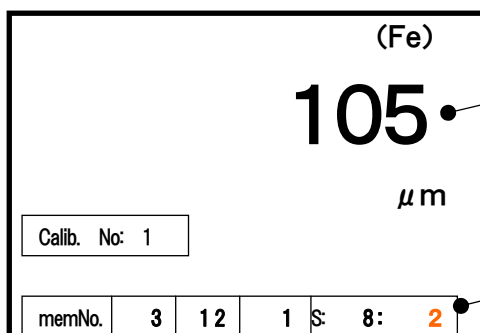

A measured result is indicated.

The number in a stored place advances to 2
A data measured now is stored in a 「1」.

A number advances by one each time a measurement is taken.

When reaching 「8」, indications are as follows :

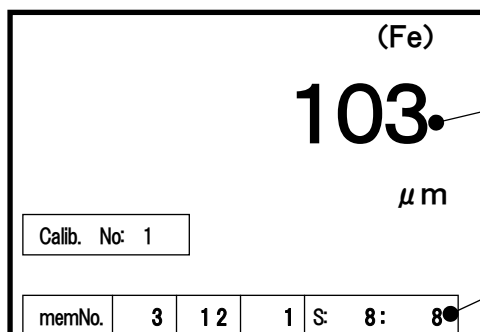

A measured result is indicated.

A number in a storing place advances to「8」.

7 pieces of Data measured are stored in places from
the numbers of 「1」 to 「7」.

A measurement is taken.

The buzzer beeps.



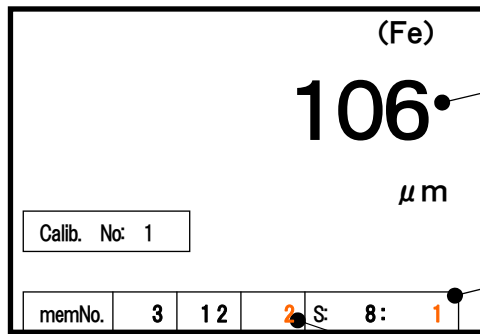

A measured result is indicated.

The number in a storing place returns to 「1」.



When 「Section No: 1」 is filled, it moves in order on to 「Section No.: 2」 and data is stored in the previous place each time a new measurement is taken.

In a next case, As measurement data have been stored , they reached to a 「Section No.: 10」、 a 「Data No.: 8」:

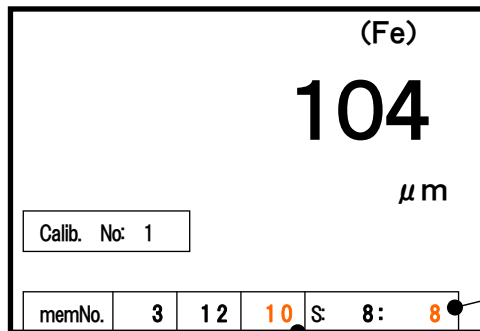

A storing place turns 「8」.



A section No. turns 「10」.

A measurement is taken.
The buzzer beeps.

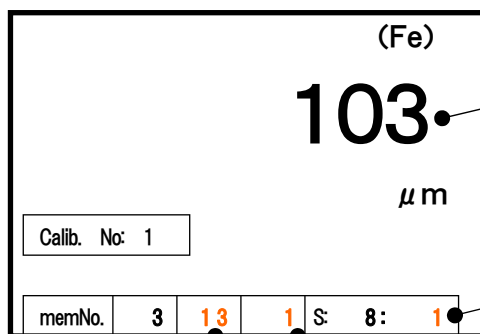

A measurement result is indicated.

The number in a storing place returns to 「1」.

A section number returns to 「1」.

A block no. advances by one to「13」.

A storing place of 「Block no.: 12」(= 8 data/section × 10 section = 80) becomes full of measured data , and then accordingly in order moves forward to a 「Block no. :13」 each time measuring is taken.

When reaching to a 「Block No.: 20」、a 「Section No.: 10」、
 A 「Data No.: 8」:

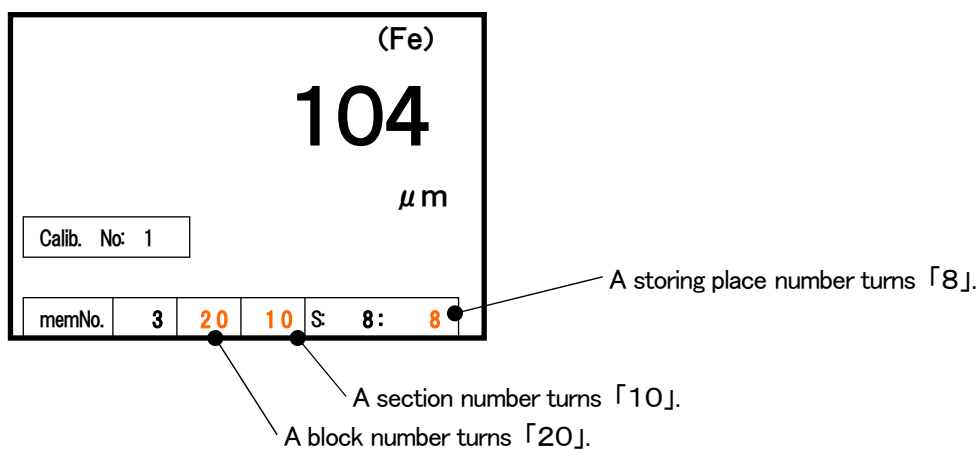

↓
 A measurement is taken.
 The buzzer beeps.

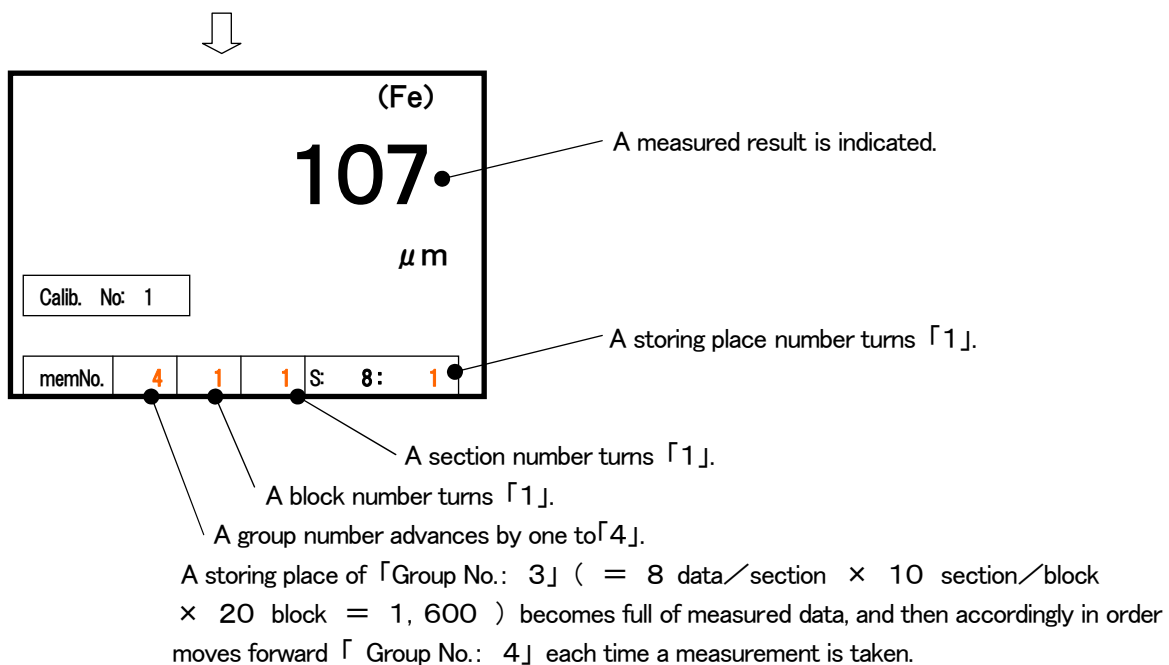

- ◆ When reaching to a 「Group No. : 5 」
 a 「Block No.: 20」、a 「Section Number: 10」、a 「Data Number: 8」.

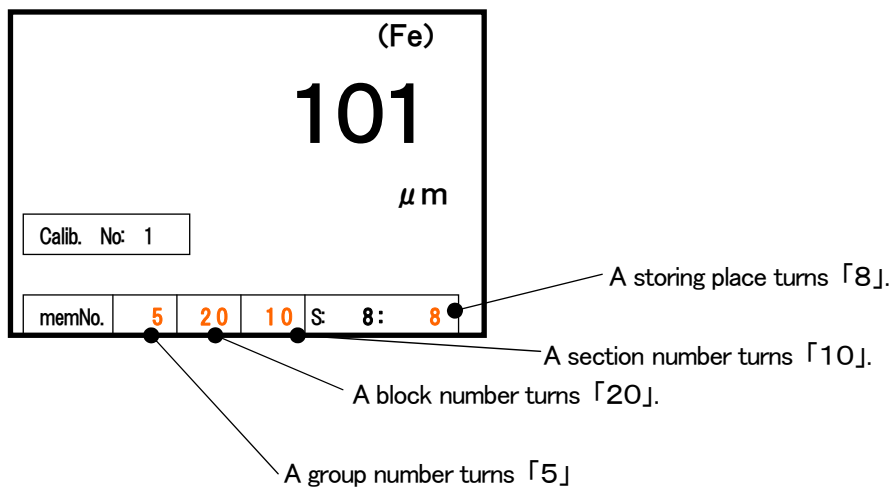

↓
A measurement is taken.
The buzzer beeps.
↓

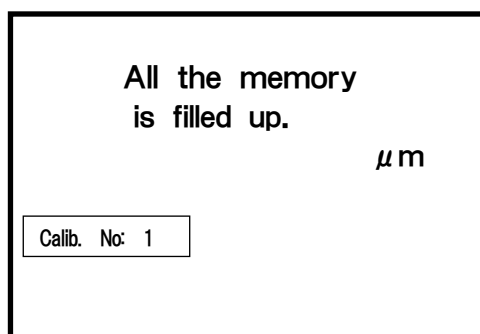

◆ There hereafter are 3 kinds of measurement methods.

(1) Continuing measurements

- Measuring
The buzzer beeps.

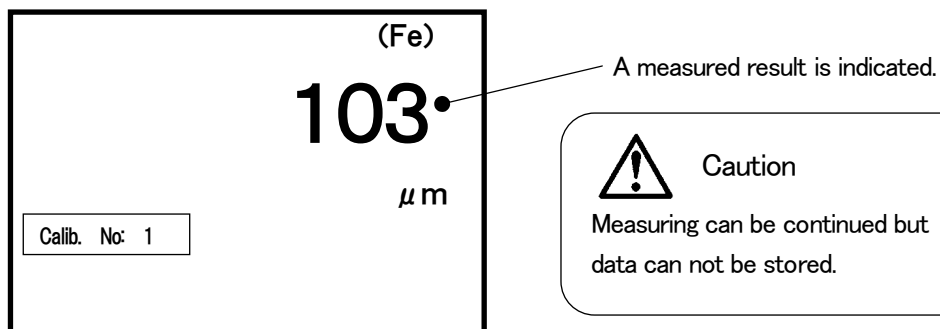

(2) Looking for an empty storing place

- Interrupt measuring.
- According to 「How to select a data storing place」 procedures on page 36 select an unoccupied place.

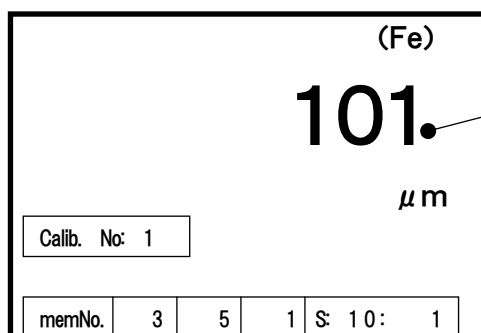

If data is stored in a selected place, the value is indicated.

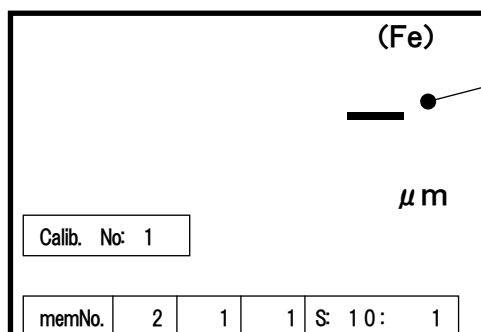

If a selected place is unoccupied, 「—」 mark is indicated.



Caution

As depending on measurement quantities, 5~6 blocks (500~600 : storing quantity) recommended for selecting as empty places to store successively.

Measuring resumed.

The buzzer beeps.

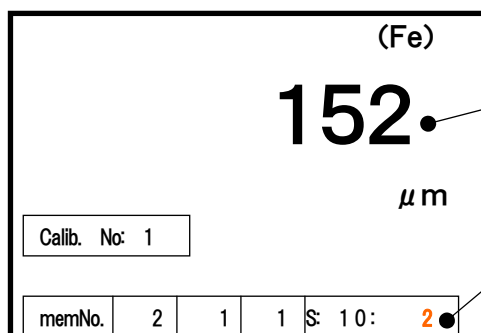

A measured value is indicated.

A measured value is stored and advances the number of a storing place by one.

(3) Deleting an unnecessary data

- Delete an unnecessary data in a storing place and store there new data which is to be taken.
- When all stored data is unnecessary, delete all of them.
- Refer to 「Deletion of data」 on page 46 to delete.
- Resume 「Measurements in storing data」 procedures afterward.

1 Deletion of data

Inadvertently pressing a probe against objectives, poor and unstable press on objects make erroneous data which are stored can be deleted.

Erroneous value is indicated.

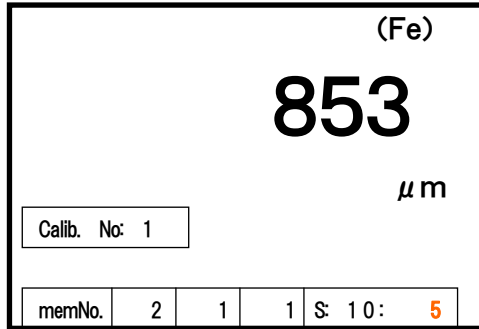

Press **DATA ERASE** key.

The buzzer beeps.

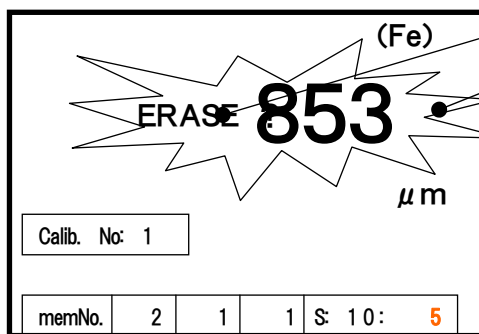

「ERASE ? 」 appears on the screen.

The measured value flashes.



Caution

A measured value flashes for about 10 sec.

Press **DATA ERASE** key during a time of 10 sec. otherwise the buzzer beeps, beeps to stop flashes and returns to a 「Measurements and adjustments」 stage.

If data deletion is necessary, try again pressing **DATA ERASE** key to start.

Press **DATA ERASE** key.

The buzzer beeps.

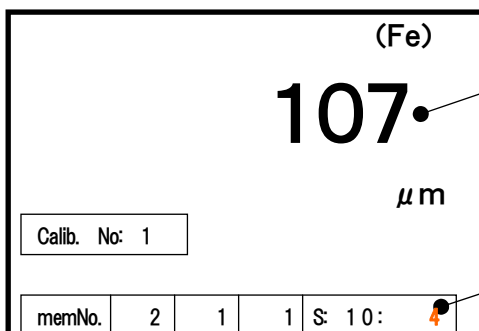

A last data (one step before) is indicated.

A storing place number returns to the last one.

Deletion of data

When data stored in a storing place are no more necessary, it is possible to delete them and store new data.
(deletion of data)

(1) Deletion of 『all data』 stored

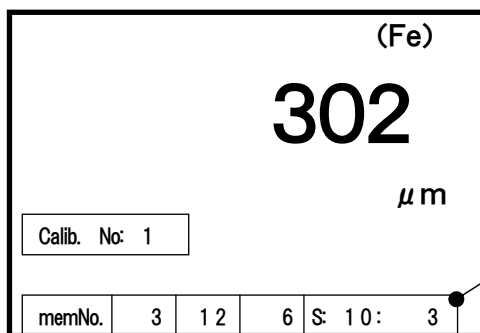

(Indication example)



Caution

Make sure that a data storing column is indicated. If it is not indicated, press **MEM.-SEL** key to activate the indication.

Press **MEM.CLEAR** key.
The buzzer beeps, beeps.



Caution

The message of deletion is indicated for about 10 sec. Press **MEM.CLEAR** key, otherwise the buzzer beeps, beeps, and the message disappears and this unit returns to 「Measurements and adjustments」 operation stage. If necessary to delete data, press **MEM.CLEAR** key to start up

Press **MEM.CLEAR** key.
The buzzer beeps, beeps.

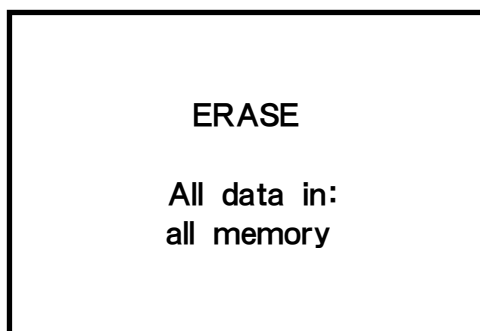

All stored data are deleted.

The buzzer beeps.



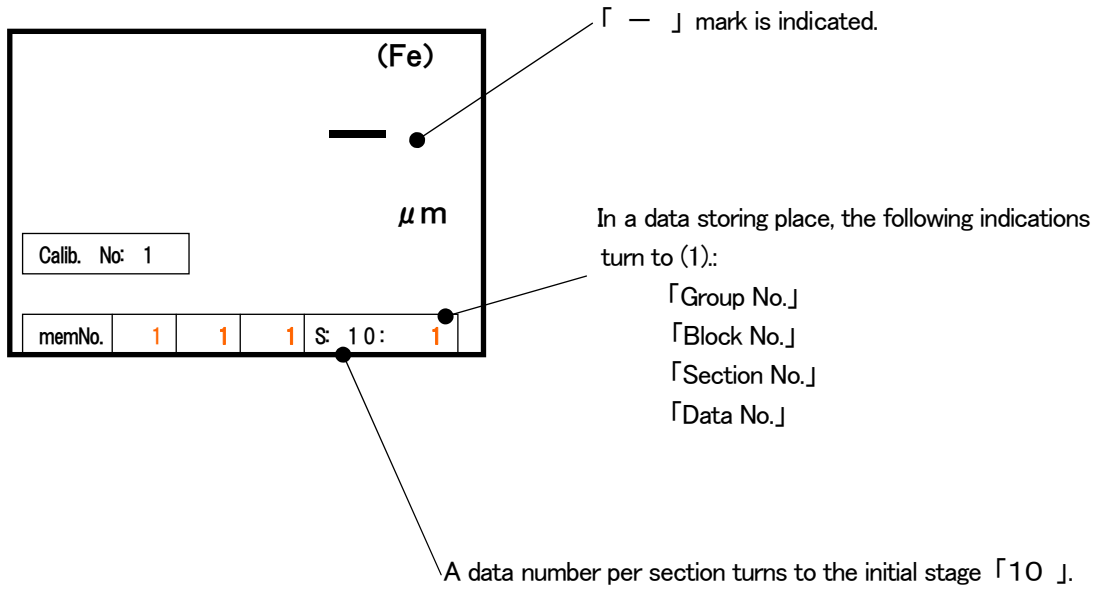

Deletion of data (group)

(2) Deletion of data stored in a 『Group No.』

Group numbers: 1~5

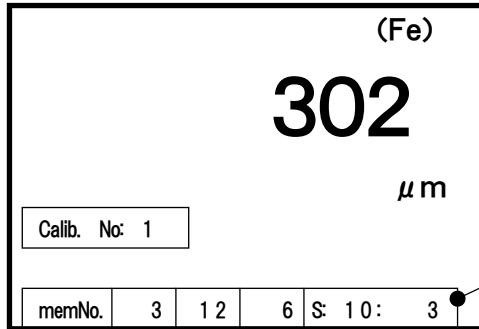

(Indication example)

An indication column of a data storing place is indicated.

Press **MEM.-SEL** key.

The buzzer beeps.

Note: When an indication column is not indicated, press

MEM.-SEL key to activate the indications.

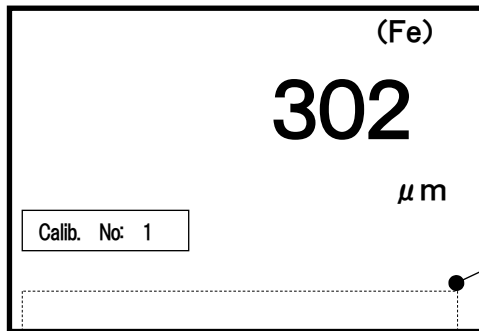

An indication column disappears.

Press **MEM.-SEL** key.

The buzzer beeps.

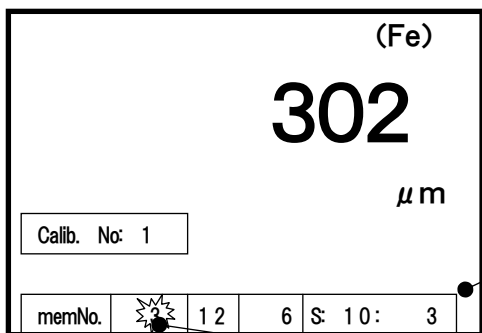

A data indication column is displayed.



A 『Group No.』 flashes.

Hold **MEM.-SEL** key and press **MEM.CLEAR** key.
The buzzer beeps, beeps.

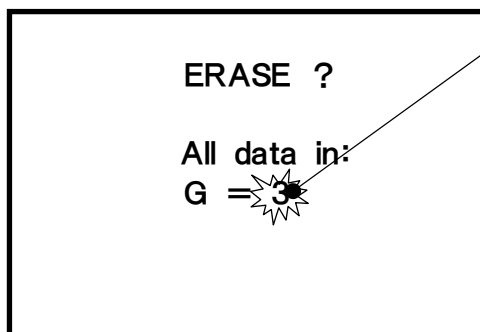

Flashes



Caution

The message is indicated for about 10 sec.
Press key during a time of 10 sec. and move to a next stage, otherwise the unit beeps, beeps and returns to (Measurements and adjustments) operation stage.

If necessary to delete data in a group no, press again **MEM.-SEL** key to start up.

Press **▲** key or **▼** key to equate data with a group no. to be deleted.

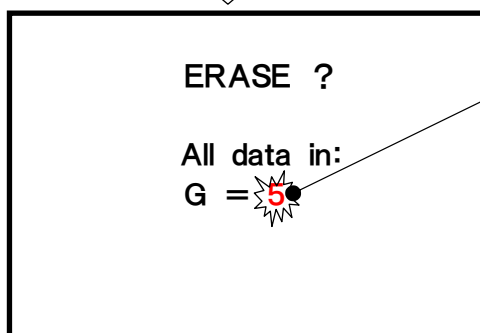

Equate with a group no. to be deleted.
(in this example, a group no. : 5.)

Press **MEM.CLEAR** key.
The buzzer beeps, beeps.

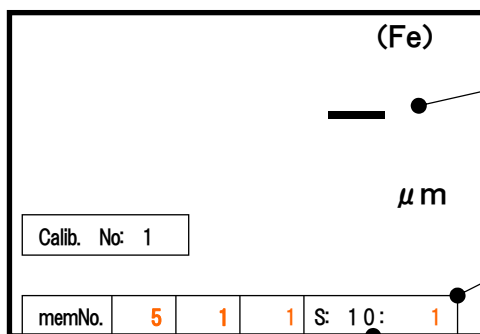

「—」 mark is indicated.

In an indication column of a data storing place, the indications are as follows:

- 「Group No.」: 「5」
- 「Block No.」: 「1」
- 「Section No.」: 「1」
- 「Data No.」: 「1」

A data number per section turns to 「10」.

Deletion of data (block)

(3) Deletion of data stored in a 『Block No.』 in a group.

Block numbers: 1~20

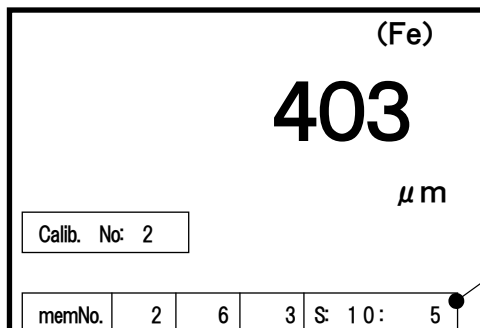

(Indication example)

An indication column of a data storing place is indicated.

Press **MEM.-SEL** key.
The buzzer beeps.

Note: When an indication column is not indicated, press **MEM.-SEL** key to activate the indications.

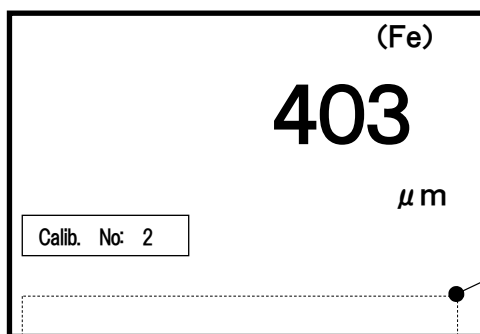

An indication column disappears.

Press **MEM.-SEL** key.
The buzzer beeps.

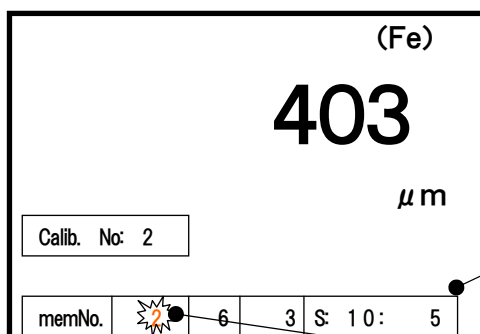

A data indication column is indicated.

『Group No.』 flashes.

Press **▲** key or **▼** key to select a group number where there is a block no. to be aimed at.



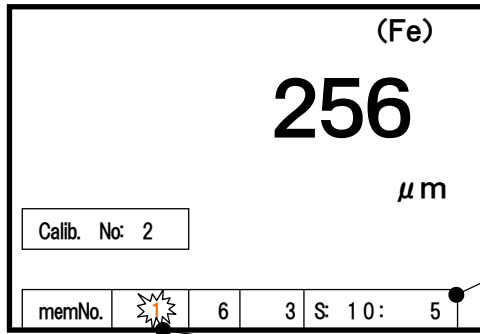

Note :When deleting data stored in a block of a group number 「1」.

A data indication column is displayed.

「Group No.」 flashes.

Press **MEM.-SEL** key.
The buzzer beeps.

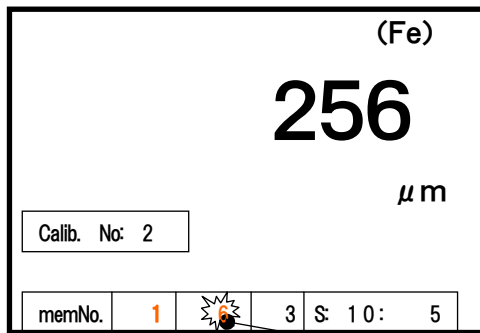

Note: When deleting data stored in a block number 「12」.

「Group No.」 is set at 「1」, and
「Block No.」 flashes.

Hold **MEM.-SEL** key and press **MEM.CLEAR** key.
The buzzer beeps, beeps.

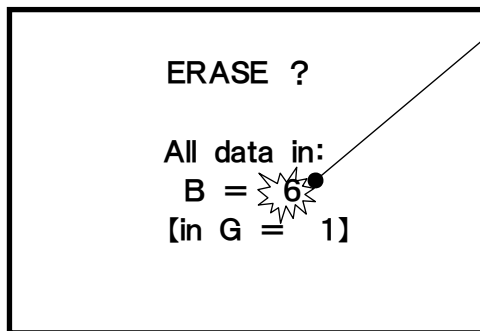

Flashes



Caution

The message is indicated for about 10 sec.
Press a key during a time of 10 sec. to move to a next stage, otherwise the buzzer beeps, beeps, and this unit returns to 「Measurements and adjustments」 operation stage.
If necessary to delete data stored in a group no. press again **MEM.-SEL** key to start up.

Press **▲** key or **▼** key to equate with a block no. where there is data to be deleted.



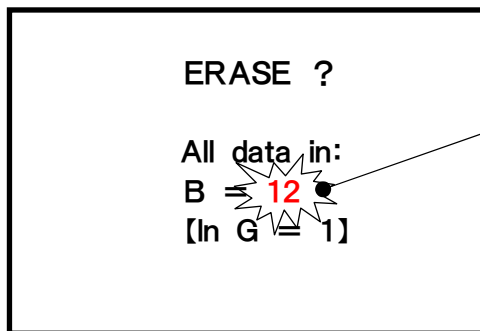

Equate with a block number to be deleted.
(In this example, a block no.: 12)

Press **MEM.CLEAR** key.
The buzzer beeps, beeps.

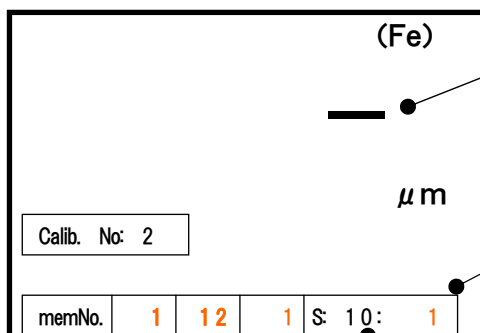

「—」 mark is indicated.

In an indication column of a data storing place,
the indications are as follow.

- 「Group No.」: 「1 」
- 「Block No.」: 「12 」
- 「Section No.」: 「1 」
- 「Data No.」: 「1 」

A data number per section turns to 「10 」.

Deletion of data (section)

(4) Deletion of data stored in a 『Section No』 in a block in a group.

Section numbers: 1~10

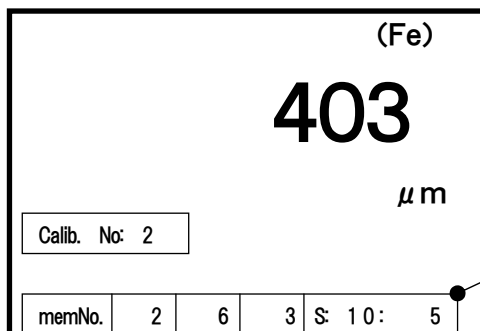

(Indication example)

An indication column in a data storing place is indicated.

Press **MEM.-SEL** key.

Note: When an indication column is not indicated, press

The buzzer beeps,

MEM.-SEL key to activate the indications.

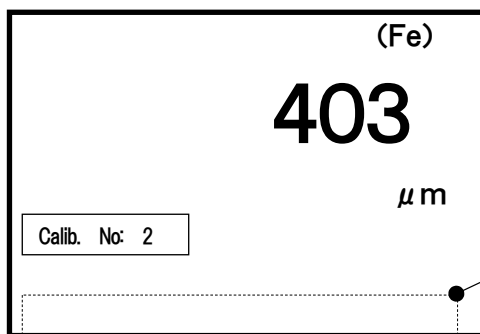

An indication column disappears.

Press **MEM.-SEL** key.

The buzzer beeps,

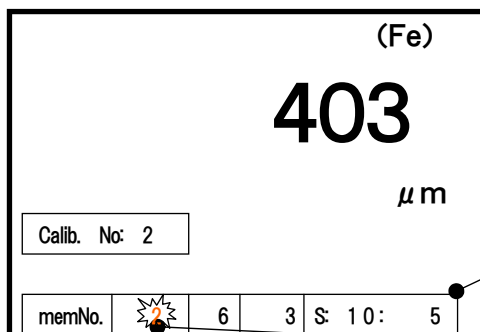

A data indication column is indicated.

「Group No.」 flashes.

Press **▲** key or **▼** key to select a group number where there is a block to be aimed at.



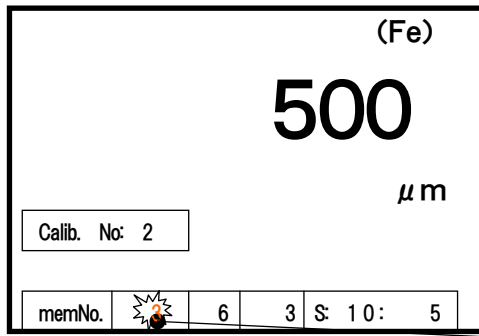

Note: When deleting data stored in a section included in a block of a group no.「3」.

「Group No.」 flashes.

Press **MEM.-SEL** key.

The buzzer beeps.

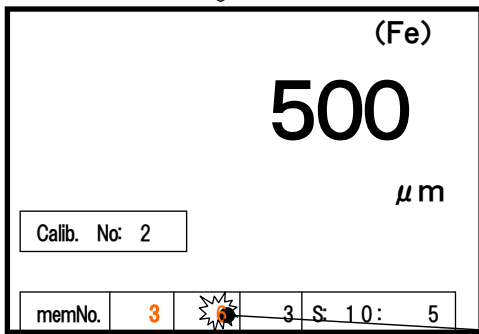

Note: When deleting data stored in a 「Section: 5」 of a block no. (7).

「Group No.」 is set at 「3」 and 「Block No.」 flashes.

Press **▲** key or **▼** key to select a block number where there is a section to be aimed at.

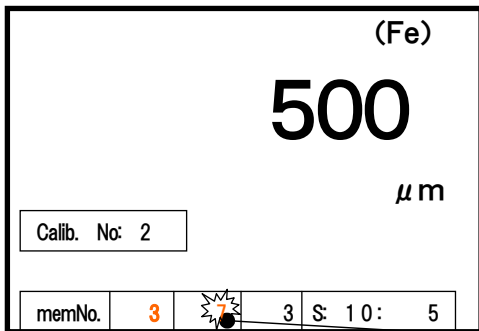

「Block No.」:「7」 flashes.

Press **MEM.-SEL** key.

The buzzer beeps.

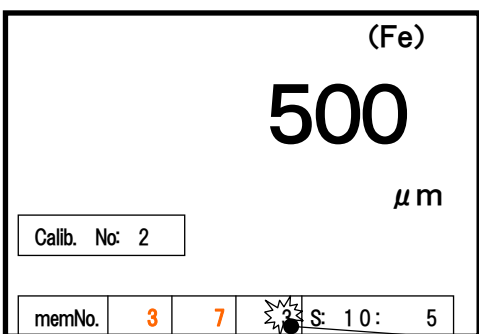

「Block No. 」 is set at 「7」.
「Section No.」:「3」 flashes.



Hold **MEM.-SEL** key and press **MEM.CLEAR** key.
The buzzer beeps, beeps.

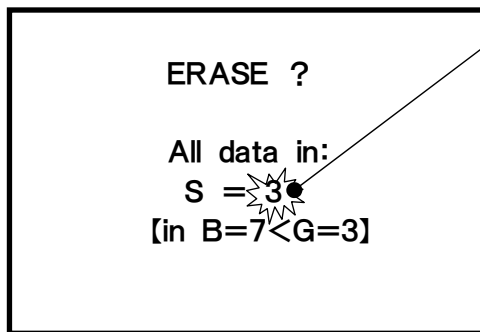

Flashes



Caution

The message is indicated for about 10 sec.
Press key during this period and move to a next stage, otherwise the buzzer beeps, beeps and this unit returns to 「Measurements and adjustments」operation stage.
If necessary to delete data stored in a group no. press again **MEM.-SEL** key to start up.

Press **▲** key or **▼** key to equate with a section number where there is data to be deleted.

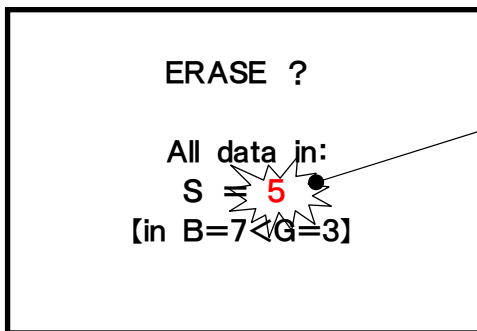

Equate with a section number to be deleted.
(in this example, section no:5)

Press **MEM.CLEAR** key.
The buzzer beeps, beeps.

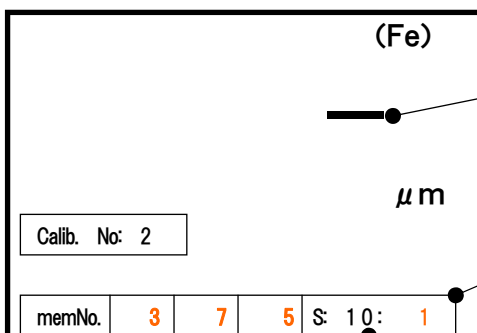

「—」 mark is indicated.

The following data are indicated:

- 「Group No.」: 「3」
- 「Block No.」: 「7」
- 「Section No.」: 「5」
- 「Data No.」: 「1」

A data number per section turns to 「10」.

Statistics

(1) Statistics of 『all data』 stored (statistical calculation value of data is indicated)

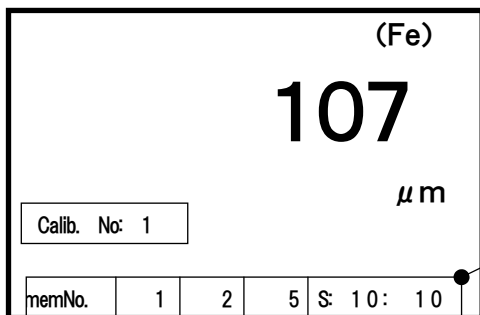

Information in a storing place is indicated.

Press **STATIS-TICS** key.
The buzzer beeps, beeps.

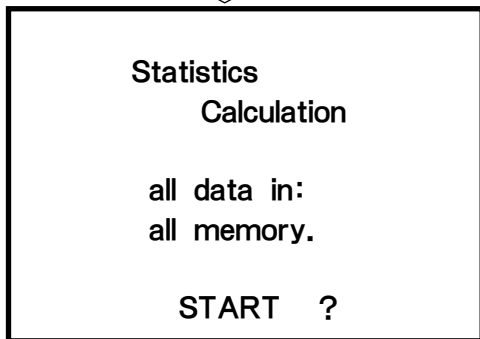

Caution

The message is indicated for about 10 sec.
Press **STATIS-TICS** key (the 2nd time),
otherwise the buzzer beeps, beeps, and this unit
returns to 「Measurements and adjustments」
operation stage.
If necessary to take statistical calculations,
try again pressing **STATIS-TICS** key
to start up.

Press **STATIS-TICS** key.
The buzzer beeps, beeps, beeps (under process of calculations).

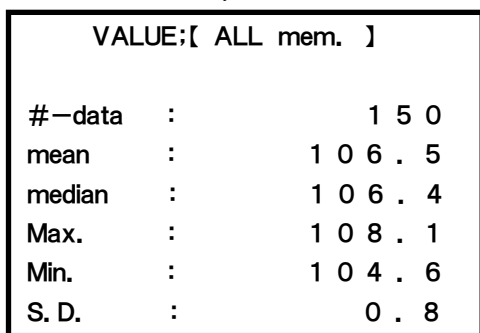

Press **STATIS-TICS** key.
The buzzer beeps.

Note: Keeping **STATIS-TICS** key from being
pressed and left alone, this stage remains
unchanged until 「Auto Power Off」 switches
Power off.

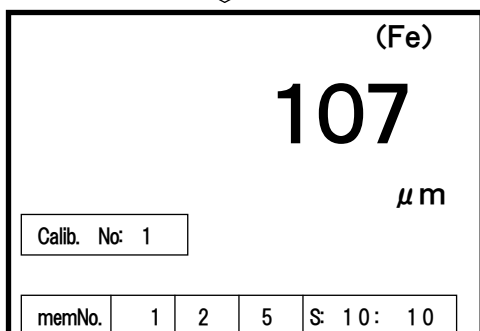

Returning to a stage before statistical calculations

(2) Statistics of data stored in 『Group No.』.

Group numbers : 1~5

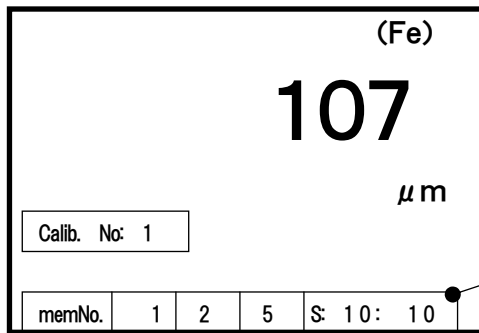

In case of statistical operations of data stored in a group number 「3」.

Information in a storing place is indicated.

Press **STATIS-TICS** key.
The buzzer beeps, beeps.

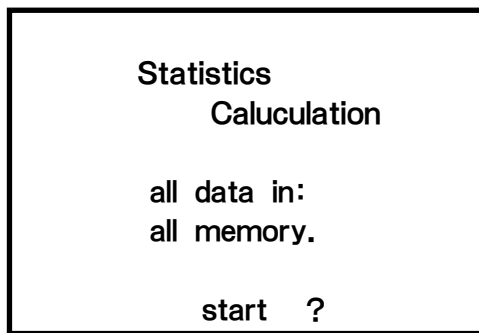

Caution

The message is indicated for about 10 sec.
Press key during this period, otherwise the buzzer beeps, beeps, and the unit returns to 『Measurement and adjustments』 operation stage.
If statistical calculation is necessary, try again pressing **STATIS-TICS** key to start up

Press **MEM.-SEL** key.
The buzzer beeps.

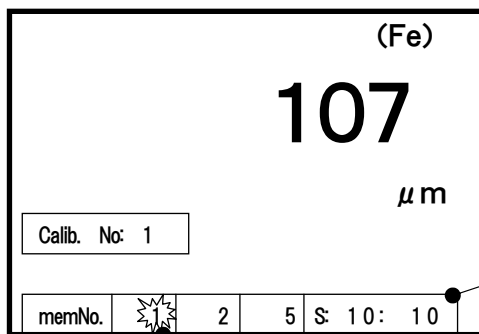

Information in a storing place is indicated.

A group no. flashes.

Press **▲** key or **▼** key to equate with a group number storing data of statistical calculations.



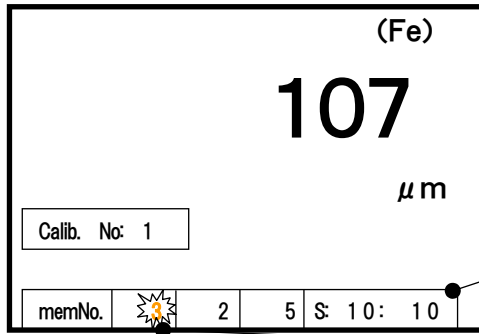

In case of statistical operations of data stored in a group number「3」

Information in a storing place is indicated.

Equate with a group no.「3」.

Press **STATIS-TICS** key.

The buzzer beeps, beeps.

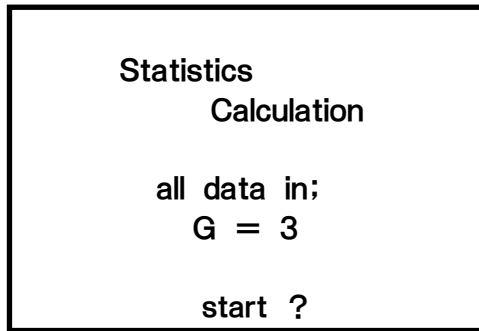

Caution

The message is indicated for about 10 sec. Press key during this period, otherwise the buzzer beeps, beeps, and the unit returns to 「Measurement and adjustments」 operation stage. If statistical calculations are necessary, try again pressing **STATIS-TICS** key to start up.

Press **STATIS-TICS** key.

The buzzer beeps, beeps, beeps (under process of calculations)

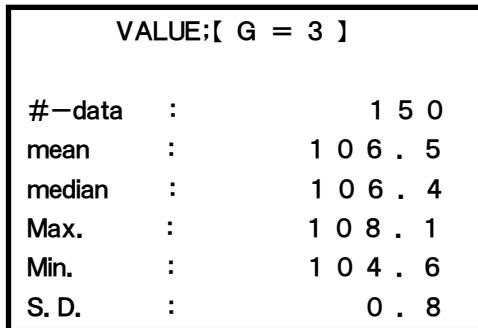

Note: Keeping **STATIS-TICS** key from being pressed and left alone, the stage remains unchanged until 「Auto Power Off」 switches Power off.

Press **STATIS-TICS** key.

The buzzer beeps.

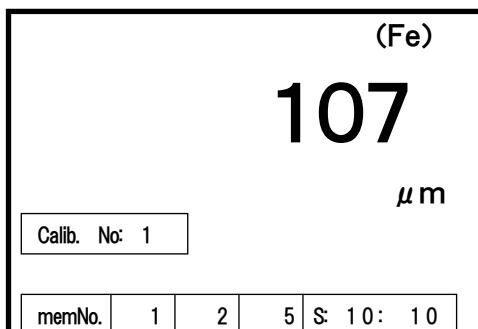

Returning to the stage before statistical calculations.

(3) Statistics of data stored in a 『Block No.』 of a group

Block numbers : 1~20

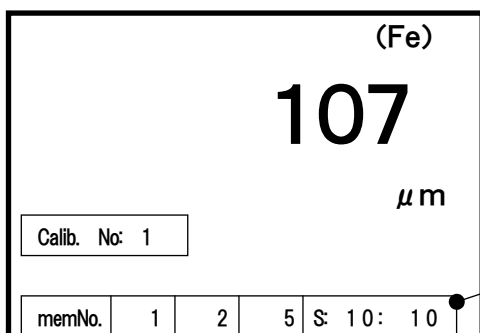

In case of statistical operations of data stored in a block no. 「14」 of a group no. 「1」.

Information in a storing place is indicated.

Press **STATIS-TICS** key.
The buzzer beeps, beeps.

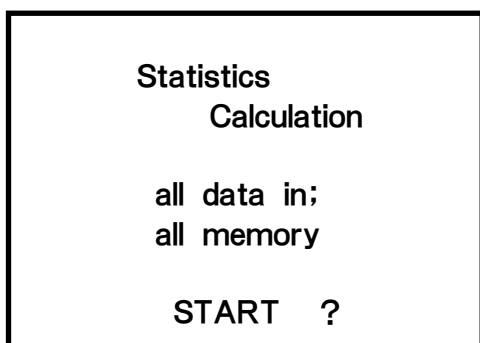

Caution

The message is indicated for about 10 sec
Press key during this period to move to a next stage, otherwise the buzzer beeps, beeps, and this unit returns to 『Measurements and adjustments』 operation stage. If statistical calculations are necessary, press **STATIS-TICS** key again to start up.

Press **MEM.-SEL** key.
The buzzer beeps.

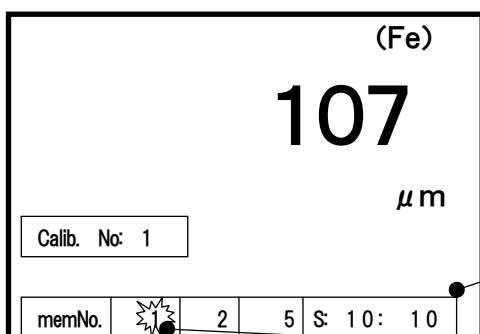

Information in a storing place is indicated.

A group no. flashes.

Press **▲** key or **▼** key to equate with a group no. to calculate statistics.



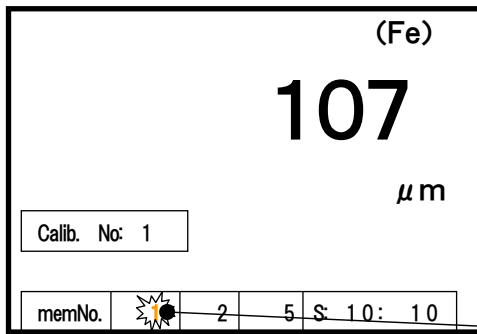

Equate with a group number「1」.

Press **MEM.-SEL** key.

The buzzer beeps.

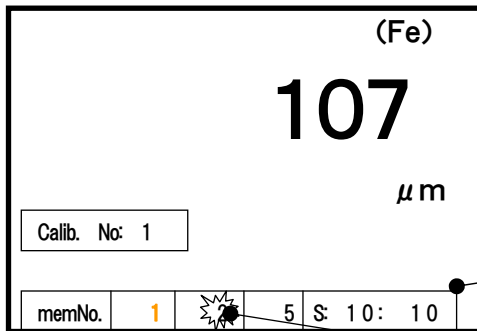

In case of statistical operations of data stored in a block no. 「14」 of a group no.「1」.

Information in a storing place is indicated.

A group no.「1」 is set and a block no. flashes.

Press **▲** key or **▼** key to equate with a block no. to calculate statistics.

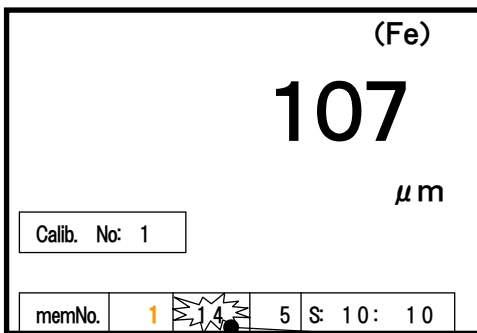

Equate with a block no.「14」.

Press **STATIS-TICS** key.

The buzzer beeps, beeps.

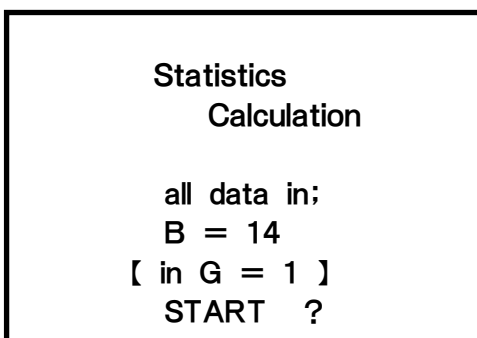

Press **STATIS-TICS** key.

The buzzer beeps, beeps, beeps (under process of calculations)



VALUE:[B = 14]			
[in G = 1]			
#-data	:		5 0
Mean	:	1 0 6 . 2	
Median	:	1 0 6 . 1	
Max.	:	1 0 7 . 5	
Min.	:	1 0 4 . 6	
S. D.	:	0 . 7	

Note : Keeping **STATIS-TICS** key from being pressed and left alone, the stage unchanges remained until 「Auto Power Off」 switches Power off.

Press **STATIS-TICS** key.

The buzzer beeps.



				(Fe)
				107
				μm
Calib. No: 1				
memNo.	1	2	5	S: 10: 10

Returning to the stage before statistical calculations.

(4) Statistics of data stored in a 『Section No.』 in a block of a group.

Section numbers: 1~10

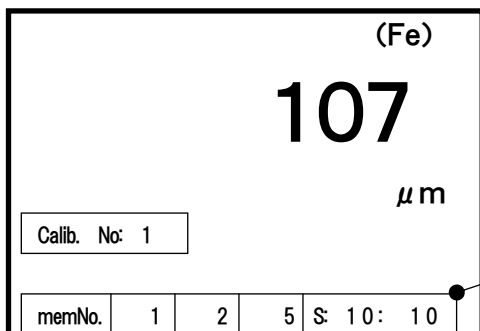

In case of data stored in a section no.『1』 in a block no.『2』 of a group no.『5』.

Information in a storing place is indicated.

Press **STATIS-TICS** key.

The buzzer beeps, beeps.

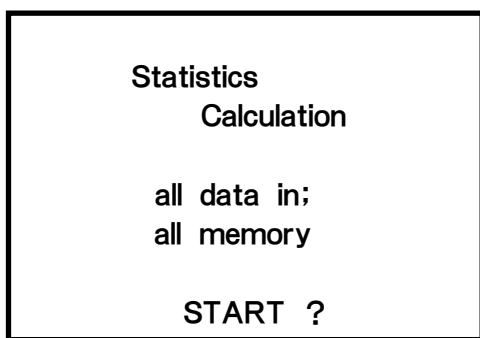

Caution

The message is indicated for about 10 sec. Press key during this period to move to a next stage, otherwise the buzzer beeps, beeps, and returns to 『Measurements and adjustments』 stage. If statistical calculations are necessary, press again **STATIS-TICS** key to start up.

Press **MEM.-SEL** key.

The buzzer beeps.

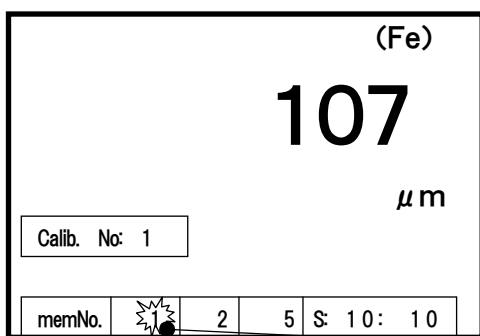

A group no. flashes.

Press **▲** key or **▼** key to equate with a group no. to calculate statistics.



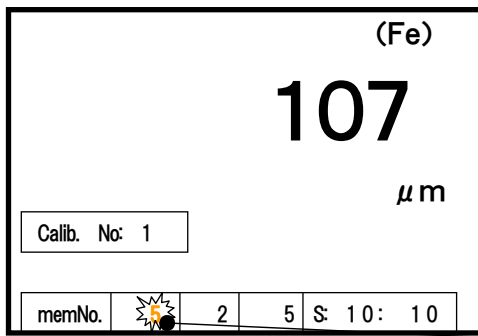

Equate with a group no.「5」.

Press **MEM.-SEL** key.

The buzzer beeps.

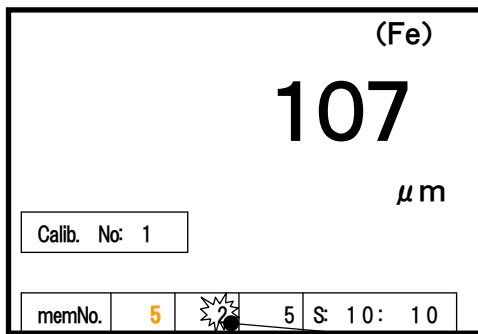

A group no.「5」 is set and a block no. flashes.

Press **▲** key or **▼** key to equate with a block no. to calculate statistics.

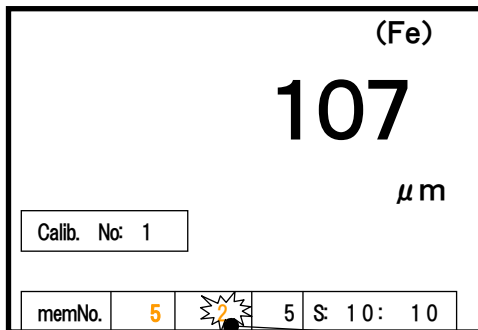

Equate with a block no.「2」.

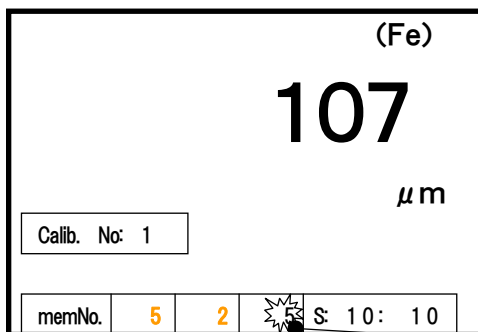

Press **MEM.-SEL** key.

The buzzer beeps.



A block no.「2」 is set and a section no. flashes.



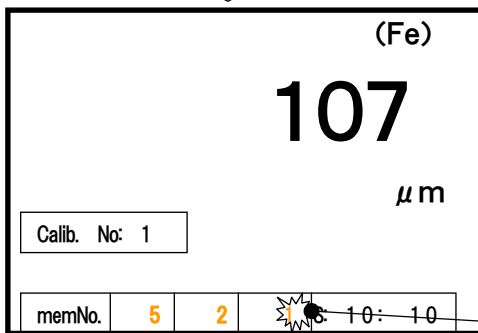

Press  key or  key to equate with a section no. to calculate statistics.

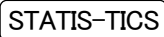

Equate with a section no.「1」.
A section no. flashes.

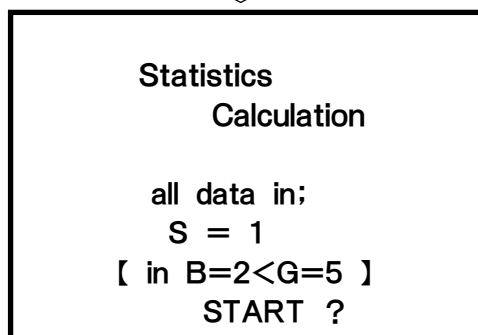
Press  key.
The buzzer beeps, beeps.



 **Caution**

The message is indicated for about 10 sec.
Press key during this period to move to a next stage, otherwise the buzzer beeps, beeps and the unit returns to 「Measurements and adjustments」stage. If statistical calculations are necessary, press again  key to start up.

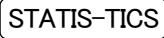
Press  key.
The buzzer beeps, beeps, beeps.
(under process of calculations)

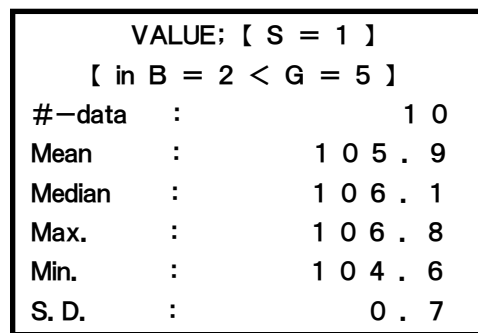

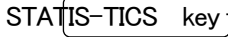
Note : Keeping  key from being pressed and left alone, the stage unchanged remained until 「Auto Power Off」 switches Power off.

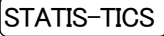
Press  key.
The buzzer beeps.

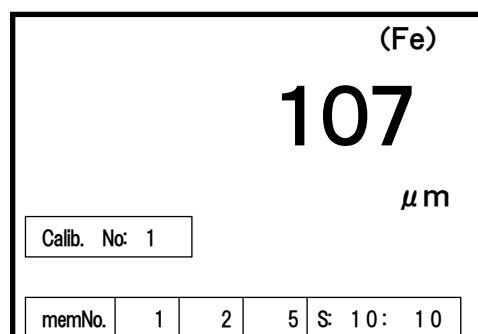

Returning to the stage before statistical calculations.

Transferring data—① (USB)

Transfer data to a PC (personal computer) by using a USB cable

Refer to separately attached information for arrangements to install a driver into a PC side.

(1) Outright transferring measured data (real time transfer)

- Prepare for a PC side.
- Connect a USB cable to a PC.

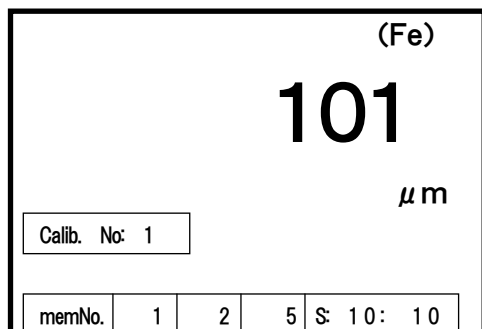

Press **COM.ENABLE** key.
The buzzer beeps.

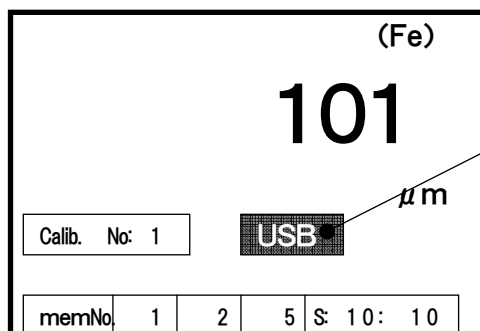

A reversal display **USB** is indicated on screen.

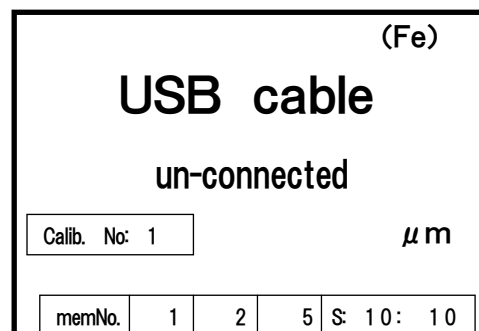

Press **TRANS-MIT** key.
The buzzer beeps.

Data is sent out each time a measurement is taken.



Caution

Pressing **COM.ENABLE** key without connecting a USB cable, a warning letter

「USB cable un-connected」 as above is indicated.

Press again **COM.ENABLE** key and connect the USB cable.

(2) Interrupt transferring data

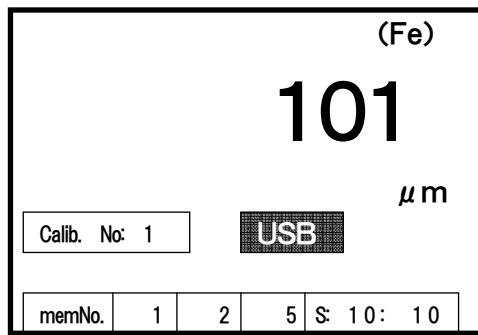

Press **COM.ENABLE** key.

The buzzer beeps.

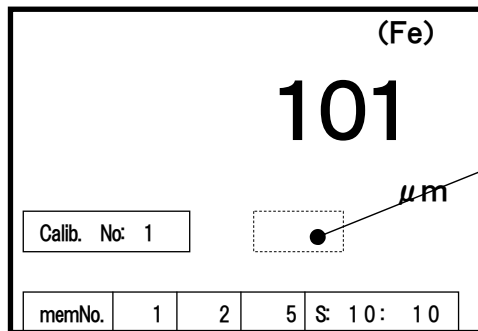

A reversal display **USB** disappear on screen.

Data stops being transferred.

Transferring stored data—② (USB)

(3) Transferring stored 『all data』.

- Prepare for a PC side
- Connect a USB cable to a PC.

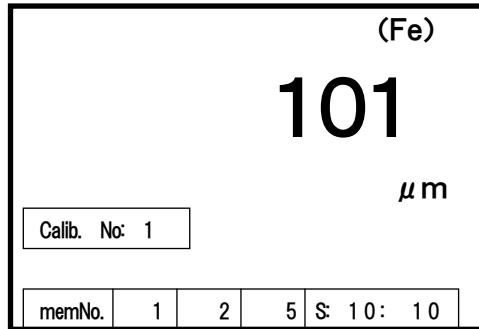

Press **COM.ENABLE** key.

The buzzer beeps.

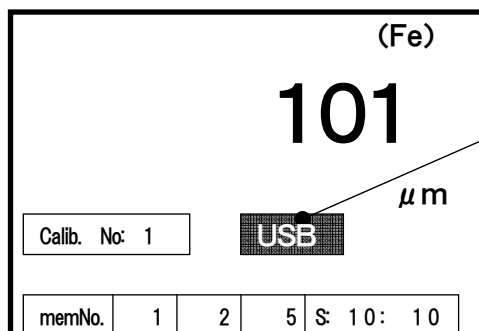

A reversal display **USB** is indicated on screen.

Note:

Pressing **COM.ENABLE** key without connecting a USB cable, a warning 「USB cable un-connected」 is indicated. Press again **COM.ENABLE** key and connect the USB cable.

Press **MEM.-SEL** key.

The buzzer beeps, beeps.

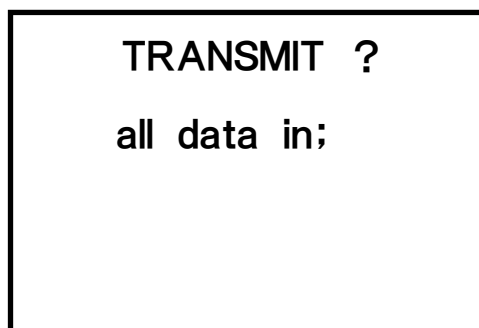

Caution

The message is indicated for about 10 sec.
Press key during this period to move to a next stage, otherwise the buzzer beeps, beeps and returns to 「Measurements and adjustment」state.

If it is necessary to send out data, press

COM.ENABLE key to display **USB**

to start up.

Press TRANS-MIT key.
The buzzer beeps, beeps.



TRANSMITTING.

all data in;

《 Transferring has completed 》

The buzzer beeps.



(Fe)

101

μm

Calib. No: 1

memNo.	1	2	5	S: 10:	10
--------	---	---	---	--------	----

Returning to the beginning.

Transferring stored data—③ (USB)

(4) Transferring data stored in a 『Group No.』.

- Prepare for a PC side.
- Connect a USB cable to a PC.

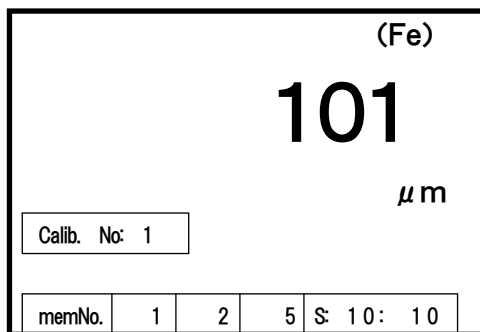

Press **COM.ENABLE** key.
The buzzer beeps.

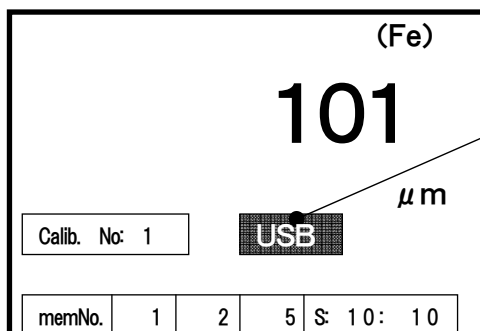

A reversal display **USB** is indicated on screen.

Note :
Pressing **COM.ENABLE** key without connecting a USB cable, a warning『USB cable un-connected』 is indicated. Press again **COM.ENABLE** key and connect the USB cable.

Press **MEM.-SEL** key.
The buzzer beeps, beeps.

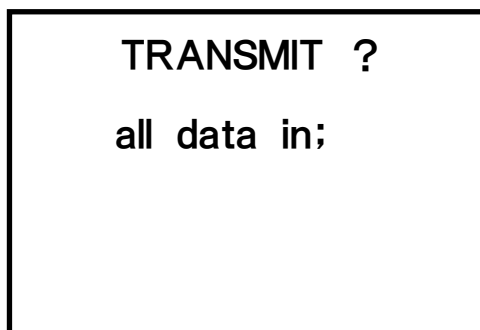

Caution

The message is indicated for about 10 sec.
Press key during this period to move to a next stage, otherwise the buzzer beeps, and this unit returns to 『Measurements and adjustments』 stage.
If it is necessary to send out data, press again **COM.ENABLE** key to display **USB** to start up

Press **MEM.-SEL** key.
The buzzer beeps.

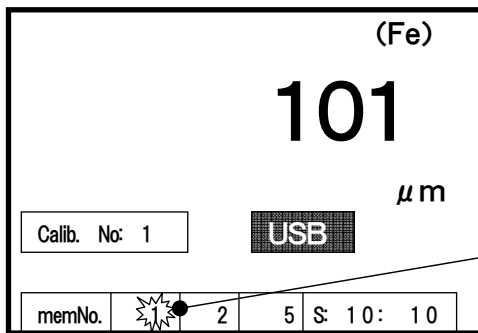

In case of transferring data stored in a group no.「3」

A group no. flashes.

Press **▲** key or **▼** key to equate
with the group no.

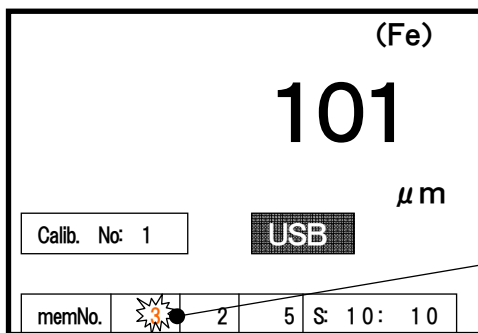

Equate with the group no.「3」.
Flashes.

Press **TRANS-MIT** key.
The buzzer beeps, beeps.

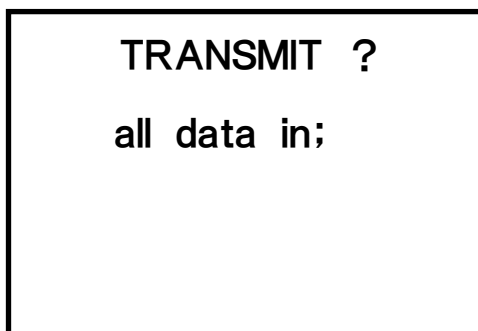

Press **TRANS-MIT** key.
The buzzer beeps, beeps.





《Transferring has completed 》

The buzzer beeps.



					(Fe)
					101
					μm
Cal. No: 1					
memNo.	1	2	5	S: 10:	10

Returning to the beginning.

Transferring stored data —④ (USB)

(5) Transferring data stored in a 『Block No.』 of a group

- Prepare for a PC side.
- Connect a USB cable to a PC.

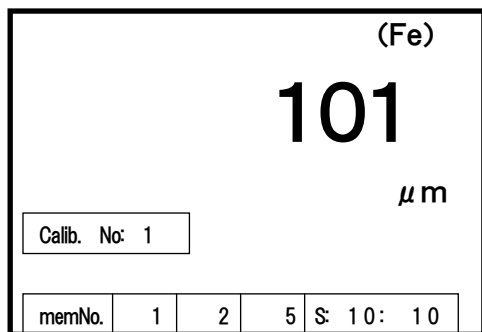

Press **COM.ENABLE** key.

The buzzer beeps.

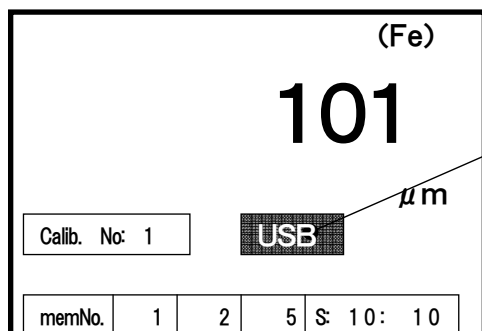

A reversal display **USB** is indicated on screen.

Note:

Pressing **COM.ENABLE** key without connecting a USB cable, a warning **【USB cable un-connected】** is displayed. Press again **COM.ENABLE** key and connect the USB cable.

Press **MEM.-SEL** key.

The buzzer beeps, beeps.

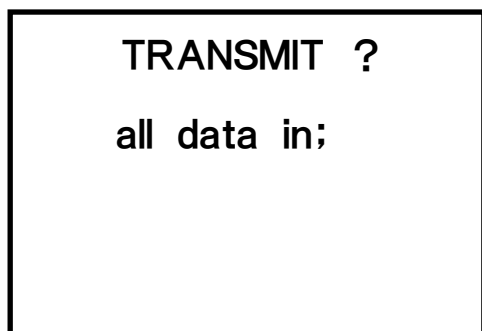

Caution

The message is displayed for about 10 sec.
Press key during this period to move to a next stage, otherwise the buzzer beeps, beeps and this unit returns to 「Measurements and adjustments」stage.
It is necessary to send out data, press again **COM.ENABLE** key to display **USB** to start up.

Press **MEM.-SEL** key.

The buzzer beeps.



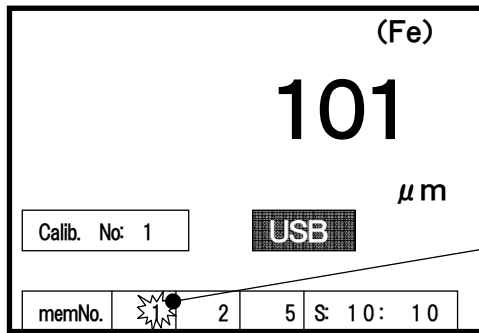

The group no. flashes.

Press key or key to equate with the group no.

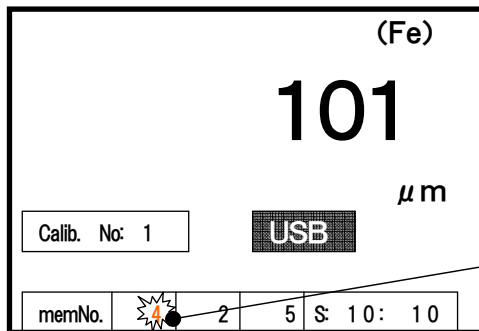

In case of transferring data stored in a block no.「7」 of a group no.「4」.

Equate with the group「4」. Flashes .

Press key.
The buzzer beeps.

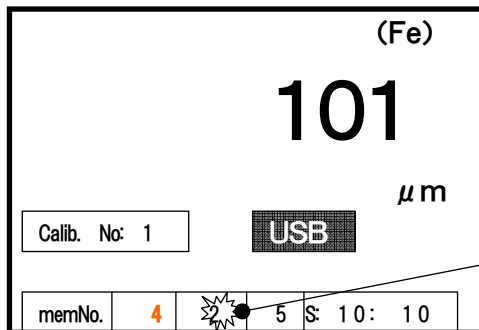

A group no. is set at「4」.
A block no. flashes.

Press key or key to equate with the block no.

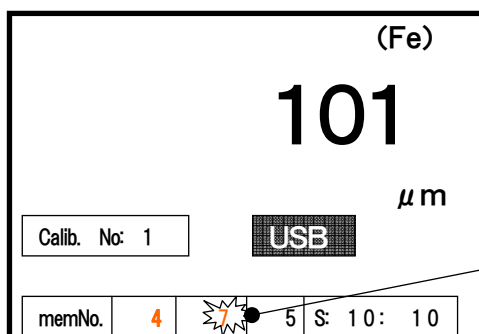

Equate with the block no. Flashes.



Press **TRANS-MIT** key.
The buzzer beeps, beeps.



TRANSMIT ?
all data in;
[in G = 4]

Press **TRANS-MIT** key.
The buzzer does not beep.



《 Transferring has completed 》

The buzzer beeps.



(Fe)
101
 μm
Calib. No: 1
memNo. 1 2 5 S: 10: 10

Returning to the beginning.

Transferring stored data—⑤ USB

(6) Transferring data stored in a 『Section No.』 in a block of a group.

- Prepare for a PC side.
- Connect a USB cable to a PC.

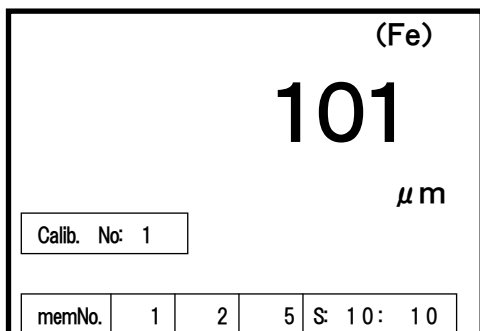

Press **COM.ENABLE** key.
The buzzer beeps.

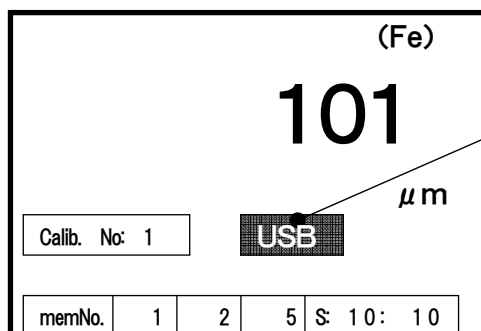

A reversal display **USB** is indicated on screen

Note :

Pressing **COM.ENABLE** key without connecting a USB cable, a warning 「USB cable un-connected」 is displayed. Press again **COM.ENABLE** key and connect a USB cable.

Press **MEM.-SEL** key.
The buzzer beeps, beeps.

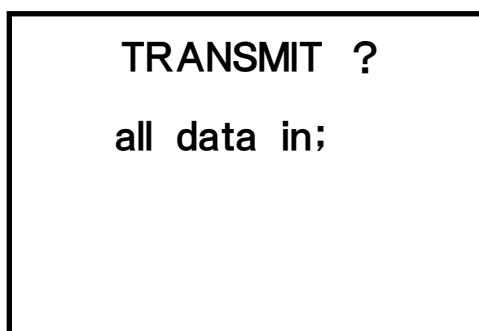

Press **MEM.-SEL** key.
The buzzer beeps.



Caution

The message is displayed for about 10 sec. Press key during this period to move to a next stage, otherwise the buzzer beeps, beeps and this unit returns to 「Measurements and adjustments」stage. If it is necessary to send out data, press again **COM.ENABLE** key to display USB to start up.

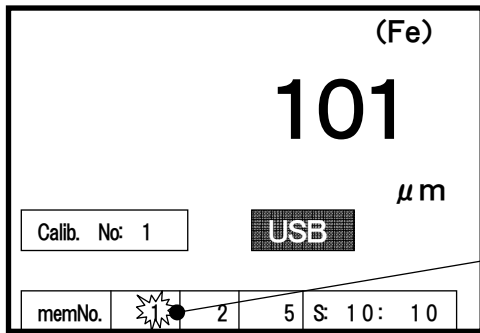

In case of transferring data stored in a section 「1」 in a block no.「8」 of a group no.「5」.

A group no. flashes.

Press key or key to equate with a group no.

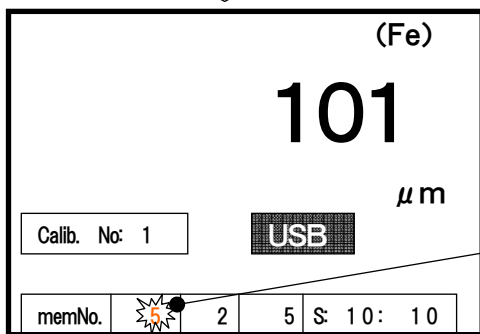

Equate with the group no. 「5」. Flashes.

Press key.

The buzzer beeps.

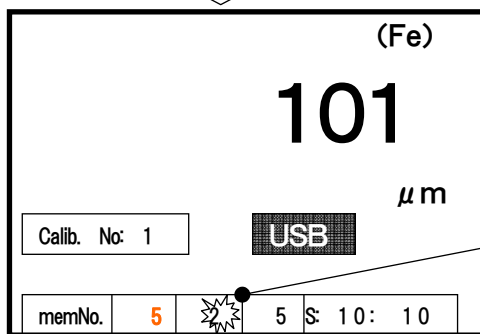

A group no. is set at 「5」 and a block no. flashes.

Press key or key to equate with a block no.

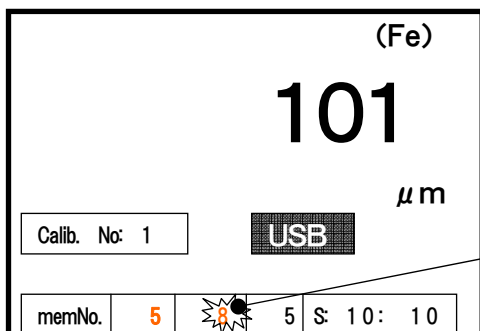

Equate with the block no. Flashes.

Press key.

The buzzer beeps.



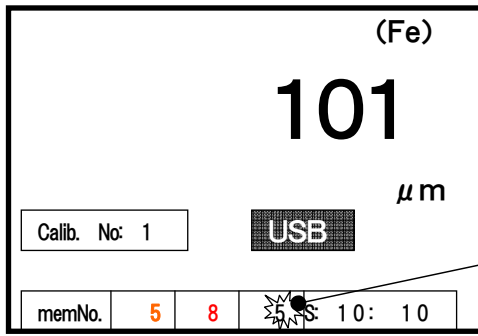

A block no. is set at 「8」.
A section no. flashes.

Press key or key to equate
with a section no.

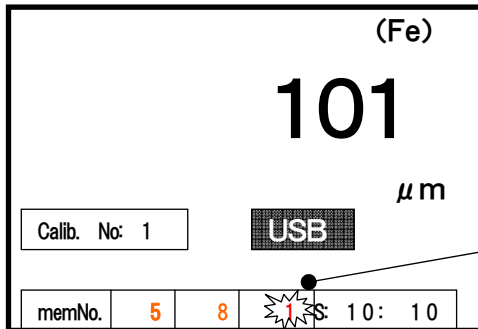

Equate with a section no.
Flashes.

Press key.
The buzzer beeps, beeps.

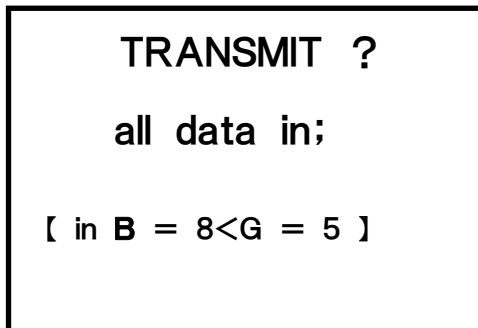

Press key.
The buzzer does not beep.





《 Transferring has completed 》

The buzzer beeps.



					(Fe)
					101
					μm
Calib. No: 1					
memNo.	1	2	5	S: 10: 10	



Returning to the beginning.

Note to improve measuring accuracy

- ① Zero plate
Prepare the same material, thick and sized plate as the measuring object for zeroing and calibration standard (CAL). Different materials may not bring about correct measuring results.
* Accessories like “zero plates for zeroing” 「for electromagnetic: SUS-430」(ferrite stainless), 「for eddy current: AL1050(aluminum)」are for testing purpose only.
Select a substrate to meet actually measuring objects.
- ② Thickness standard (plates)
Take a calibration standard measurement using a Thickness standard which is thicker or as thick as the measuring films.
* Use of a calibration standard with a deviate thickness may cause errors.
Replace worn-out or bent plates with new ones. In case non-accessorized plates are necessary (over 15 μ m), contact a local sales office.
- ③ Quality of films to be measured
Metal contained films can not correctly be measured. In case of measuring elastic films, place a standard plate of 30~50 μ m thick on the object and subtract the thickness from the measuring value to avoid errors to be caused by elastic dents.
- ④ Measurements of edges or angles
Electric fields in the neighborhood of the edges/the angles of a measuring object become uneven. 15~20 mm closer part to the center of the object shall generally be measured.
Pay attention to protruded part, curved part or unexpectedly deformed part.
- ⑤ Measurements of rough faces
Roughness of a substrate, a measuring face affects measuring results.
Take a mean value by measuring several places at a time.
- ⑥ Measurements of stretched part on faces
In some case stretched, rolled part occurred on a substrate, which may cause measuring errors.
Take a mean value by measuring several places at a time.
- ⑦ Temperature
Operating temperature range is 0~40 °C. Especially difference between a main unit and a probe causes measuring errors.
- ⑧ Residual magnetism, stray magnetic fields
Pay attention to transportation method of electromagnets, residual magnetism on substrates or arc welding, those of which emit strong magnetic fields to cause measuring errors.

Trouble Shooting

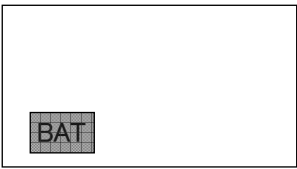
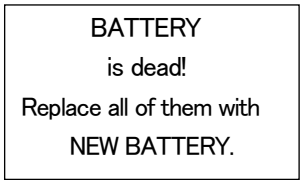
Before contacting us please check with the following points.

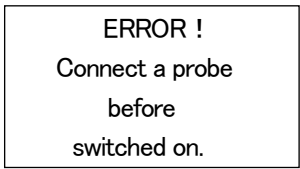
Symptoms	Points to check	Measures to be taken
No response upon press of ON/OFF key.	Are batteries worn out?	Replace them with new ones (2 ea.)
No response after replacing batteries and pressing a key	Something wrong inside a meter	Contact us for repair
	Batteries is shorting.	They can be used for a while. Prepare for new batteries.
	Batteries have worn out.	Replace them with new one
	Out of batteries	Replace new batteries
	Started pressing probe to object soon after switching on.	Hold probe in air, keeping it away off objects, metals during a time of the message on screen. .
	Press ON/OFF key without connecting probe	Press ON/OFF key after being sure of connecting probe.

Symptoms	Points to check	Measures to be taken
<div style="border: 1px solid black; padding: 5px; width: fit-content;"> <p style="text-align: center;">TROUBLE !</p> <p>The probe may have trouble. Change it to the other one.</p> <p style="text-align: center;">《Power OFF》</p> </div>	Something wrong with probe	Contact us for repairs
No response upon key entry	「LOCK」 key is pressed	Switch off, switch on again to release 「Key Lock」
No response even after releasing Key-Lock	Something wrong with unit itself	Contact us for repairs
Data can not be stored in memory	All spaces are occupied	Delete unnecessary data to make vacancies.
	A Measurement mode is set at 「Non Interrupt mode」	Press 「ZERO key and 「▲」key to correct mode
<div style="border: 1px solid black; padding: 5px; width: fit-content;"> <p>USB cable un-connected</p> </div>	USB cable is not connected	Connect a USB cable

Symptoms	Points to check	Measures to be taken
<p>Unable to transfer data with USB cable.</p>	<p>① connections of USB cable</p> <p>② receiver side with PC</p>	<p>① Ensure connections</p> <p>② (1) install attached CD Driver correctly</p> <p>(2) correct setting Virtual Comport.</p>
<p>Sudden interruption of transfer with USB cable</p>	<p>① PC side</p> <p>② Unless PC faulty, Something wrong with Unit</p>	<p>① check PC</p> <p>② contact us.</p>

Specifications

◆ Unit

Items	Applications
Model names	Dual electromagnetic/eddy current SWT-7200
Display method	Graphic LCD (data ▪ message)
Ranges	Depending on optional probes
Calibrations (CAL)	2 points calibration type Zeroing : for substrate Calibration standard: for substrate and standard thicknesses
Additional functions	<ul style="list-style-type: none"> ① Key Lock ② Auto Power Off (3 min.) ③ switching modes (hold/non interrupt) ④ switching display resolutions ⑤ total deletion of calibrations and values ⑥ numbers of calibration setting :Max. 10 ⑦ high/upper limits alarming (every each calibration) ⑧ data memory: 10, 000 data ⑨ Statistics process、 indications ⑩ USB connections
Keys	<p>ON/OFF、ZERO、▲、▼、LOCK、</p> <p>CAL No.、H/L、STATISTICS、MEM.-SEL、</p> <p>COMENABLE、TRANSMIT、MEM.CLEAR、</p> <p>DATA ERASE、CANCEL</p>
Power	3V DC (AA, R6P × 2)、(exclusive AC adaptor)
Operating Temperature	0~40°C (Non-condensing)
Accessories	Dry battery, carrying case AC adaptor, USB cable, USB driver (CD)
Optional	For ferrous substrate probe (Fe)、for nonferrous substrate probe (NFe)
Dimensions	72(W) × 30(H) × 156(D)mm
weight	200g

Sept., 2008

◆ Probes (Optional)

Models	Fe-2.5	NFe-0.6	NFe-2.0
Methods	Magnetic inducing type	Eddy current type	
Ranges	0~2.50mm	0~600 μm	0~2.00mm
Display resolutions	1 μm:0~999 μm switching to 0.1 μm:0~400 μm、 0.5 μm:400~500 μm 0.01mm:1.00~2.50mm	1 μm:0~600 μm switching to 0.1 μm:0~400 μm、 0.5 μm:400~500 μm	1 μm:0~999 μm switching to 0.1 μm:0~400 μm、 0.5 μm:400~500 μm 0.01mm:1.00~2.00mm
Accuracies (on flat face)	0~100 μm: ±1 μm Or ±2% the designated value 101 μm~2.50mm: ±2%	0~100 μm: ±1 μm Or ±2% the designated value 101 μm~600 μm: ±2%	0~100 μm: ±1 μm Or ±2% the designated value 101 μm~2.00mm: ±2%
Probes	One point contact constant pressure type, V cut φ13×48mm	One point contact constant pressure type, V cut φ11×48mm	One point contact constant pressure type, V cut φ13×47mm
	Option : V type probe adaptor (3 kinds: for φ5 less, φ5~10, φ10~20)		
Accessories	Standard thickness, Zero plate for testing (Fe)	Standard thickness, Zero plate for testing (NFe)	
Measuring objects	Coating, lining, thermal spray film, plating (except electrolyte nickel plating), etc. on magnetic metal substrates like ferrous, steel, etc.	Insulated films, etc. on non-magnetic substrates like aluminum, copper, etc.	

Reference (Principle of measurements)

● Electro-Magnetic type

When metals approach to AC- magnetic fields emitted from probe, the metal and the magnet pull each other.

It makes the pulling force stronger as they come closer.

In other words, it makes the magnetic density higher as they come closer. On the contrary, it weakens the magnetic density as they move away from each other.

This symptom means that magnetism emitted from probe has Higher Transferability when they come closer, and lower Transferability when they move away from each other.

These levels of transferability of the magnetism co-relate with thicknesses of films coated on substrates.

By analyzing correlations of transferability/less transferability (Reluctance), and thicknesses of the films on the substrates, the correlated values can be converted to the thickness , actually by measuring the Reluctance to be processed.

Because it is difficult to observe and measure magnetic volumes, it is necessary that the Reluctance volumes be converted to electric volumes using coils and methods of the Principle of Electromagnetic Induction so that the measured values can be processed and converted to the thickness values.

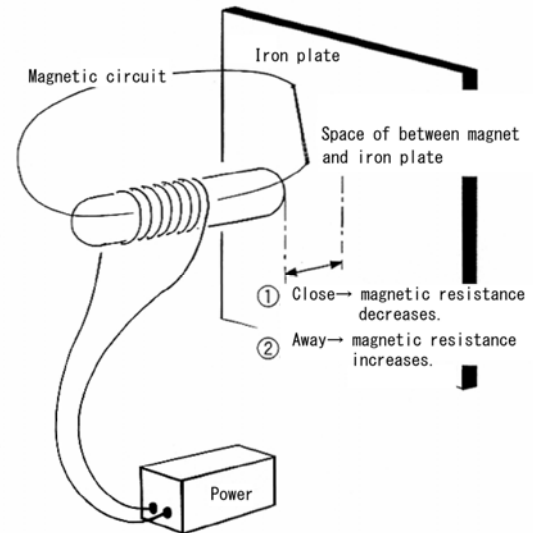

● Eddy Current Type

The eddy current is induced on the surface of metals when metals approach to alternating current fields emitted from probe.

As the metal comes closer to the probe, the eddy current increases and the magnetic field density becomes high.

On the contrary, as the metal move away from the probe, the eddy current decreases and the magnetic density becomes low: Correlations of between density of magnetic field and film thicknesses on the substrate are analyzed beforehand.

It measure the thicknesses by converting to the thickness value from the magnetic density measured through the above correlations.

Because it is difficult to observe and measure the density of a magnetic field, it is necessary that a coil be put in magnetic fields and converted to electric volumes for measurements using the Principle of Electromagnetic Induction so that the measured value can be processed and converted to the thickness value. Generally in the eddy current type, it varies in measurement range on non-magnetic substrate by dividing substrates by a high-wave transferable like Alumi and Copper and non-transferable like irons to optimize the measurement methods.

